HM538123B Series

1 M VRAM (128-kword × 8-bit)

HITACHI

ADE-203-231D (Z)
Rev. 4.0
Nov. 1997

Description

The HM538123B is a 1-Mbit multiport video RAM equipped with a 128-kword × 8-bit dynamic RAM and a 256-word × 8-bit SAM (serial access memory). Its RAM and SAM operate independently and asynchronously. It can transfer data between RAM and SAM. In addition, it has two modes to realize fast writing in RAM. Block write and flash write modes clear the data of 4-word × 8-bit and the data of one row (256-word × 8-bit) respectively in one cycle of RAM. And the HM538123B makes split transfer cycle possible by dividing SAM into two split buffers equipped with 128-word × 8-bit each. This cycle can transfer data to SAM which is not active, and enables a continuous serial access.

Features

- Multiport organization
 - Asynchronous and simultaneous operation of RAM and SAM capability
 - RAM: 128-kword × 8-bit and
 - SAM: 256-word × 8-bit
- Access time
 - RAM: 60 ns/70 ns/80 ns/100 ns max
 - SAM: 20 ns/22 ns/25 ns/25 ns max
- Cycle time
 - RAM: 125 ns/135 ns/150 ns/180 ns min
 - SAM: 25 ns/25 ns/30 ns/30 ns min
- Low power
 - Active RAM: 413 mW max
 SAM: 275 mW max
 - Standby 38.5 mW max
- High-speed page mode capability
- Mask write mode capability
- Bidirectional data transfer cycle between RAM and SAM capability
- Split transfer cycle capability
- Block write mode capability
- Flash write mode capability

HM538123B Series

- 3 variations of refresh (8 ms/512 cycles)
 - $\overline{\text{RAS}}$ -only refresh
 - $\overline{\text{CAS}}$ -before- $\overline{\text{RAS}}$ refresh
 - Hidden refresh
- TTL compatible

Ordering Information

Type No.	Access Time	Package
HM538123BJ-6	60 ns	400-mil 40-pin plastic SOJ (CP-40D)
HM538123BJ-7	70 ns	
HM538123BJ-8	80 ns	
HM538123BJ-10	100 ns	

Pin Arrangement

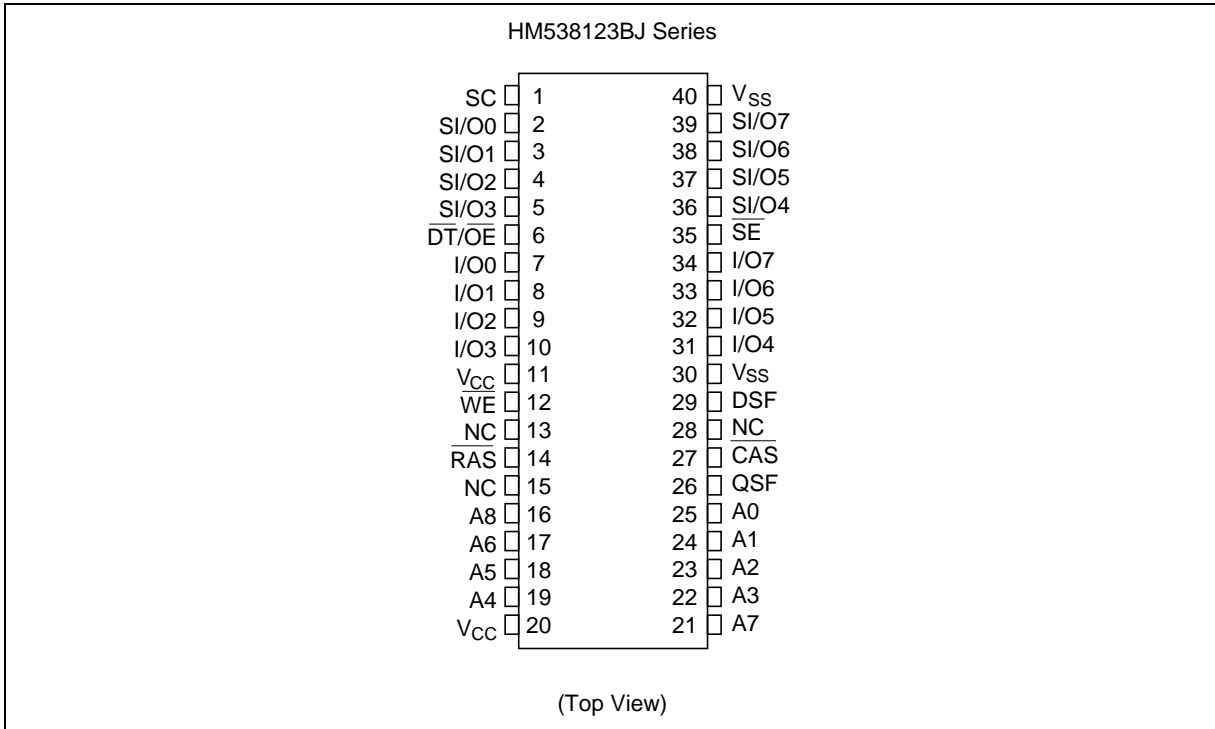

Pin Description

Pin Name	Function
A0 – A8	Address inputs
I/O0 – I/O7	RAM port data inputs/outputs
SI/O0 – SI/O7	SAM port data inputs/outputs
$\overline{\text{RAS}}$	Row address strobe
$\overline{\text{CAS}}$	Column address strobe
$\overline{\text{WE}}$	Write enable
$\overline{\text{DT/OE}}$	Data transfer/Output enable
SC	Serial clock
$\overline{\text{SE}}$	SAM port enable
DSF	Special function input flag
QSF	Special function output flag
V _{CC}	Power supply
V _{SS}	Ground
NC	No connection

HM538123B Series

Block Diagram

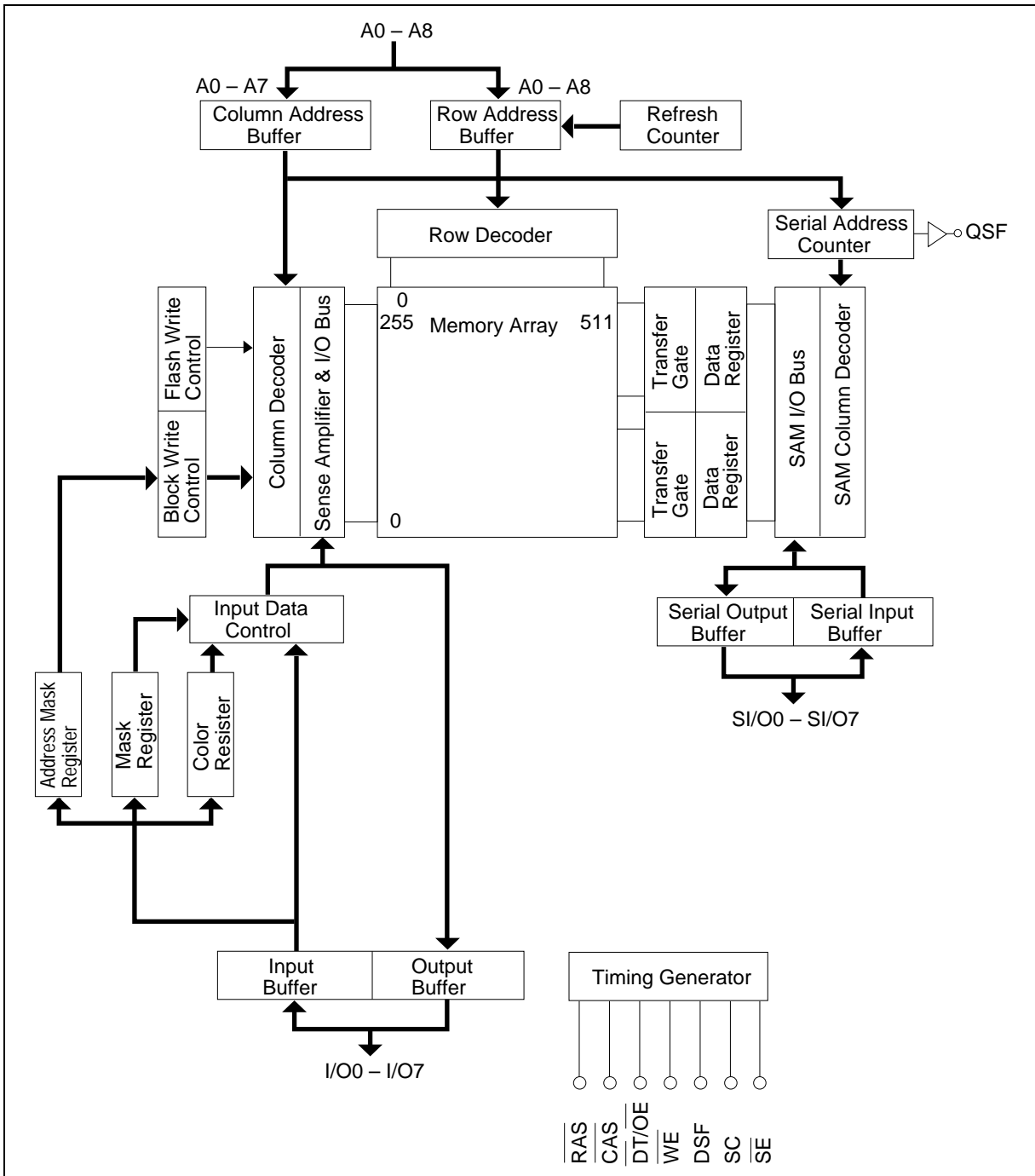

Pin Functions

$\overline{\text{RAS}}$ (input pin): $\overline{\text{RAS}}$ is a basic RAM signal. It is active in low level and standby in high level. Row address and signals as shown in table 1 are input at the falling edge of $\overline{\text{RAS}}$. The input level of these signals determine the operation cycle of the HM538123B.

Table 1 Operation Cycles of the HM538123B

Input Level At The Falling Edge Of $\overline{\text{RAS}}$

$\overline{\text{CAS}}$	$\overline{\text{DT/OE}}$	$\overline{\text{WE}}$	$\overline{\text{SE}}$	$\overline{\text{DSF}}$	DSF At The Falling Edge Of $\overline{\text{CAS}}$	Operation Mode
L	X	X	X	X	—	CBR refresh
H	L	L	L	L	X	Write transfer
H	L	L	H	L	X	Pseudo transfer
H	L	L	X	H	X	Split write transfer
H	L	H	X	L	X	Read transfer
H	L	H	X	H	X	Split read transfer
H	H	L	X	L	L	Read/mask write
H	H	L	X	L	H	Mask block write
H	H	L	X	H	X	Flash write
H	H	H	X	L	L	Read/write
H	H	H	X	L	H	Block write
H	H	H	X	H	X	Color register read/write

Note: X; Don't care

$\overline{\text{CAS}}$ (input pin): Column address and DSF signal are fetched into chip at the falling edge of $\overline{\text{CAS}}$, which determines the operation mode of HM538123B. $\overline{\text{CAS}}$ controls output impedance of I/O in RAM.

A0 – A8 (input pins): Row address (AX0 – AX8) is determined by A0 – A8 level at the falling edge of $\overline{\text{RAS}}$. Column address (AY0 – AY7) is determined by A0 – A7 level at the falling edge of $\overline{\text{CAS}}$. In transfer cycles, row address is the address on the word line which transfers data with SAM data register, and column address is the SAM start address after transfer.

$\overline{\text{WE}}$ (input pin): $\overline{\text{WE}}$ pin has two functions at the falling edge of $\overline{\text{RAS}}$ and after. When $\overline{\text{WE}}$ is low at the falling edge of $\overline{\text{RAS}}$, the HM538123B turns to mask write mode. According to the I/O level at the time, write on each I/O can be masked. ($\overline{\text{WE}}$ level at the falling edge of $\overline{\text{RAS}}$ is don't care in read cycle.) When $\overline{\text{WE}}$ is high at the falling edge of $\overline{\text{RAS}}$, a normal write cycle is executed. After that, $\overline{\text{WE}}$ switches read/write cycles as in a standard DRAM. In a transfer cycle, the direction of transfer is determined by $\overline{\text{WE}}$ level at the falling edge of $\overline{\text{RAS}}$. When $\overline{\text{WE}}$ is low, data is transferred from SAM to RAM (data is written into RAM), and when $\overline{\text{WE}}$ is high, data is transferred from RAM to SAM (data is read from RAM).

HM538123B Series

I/O0 – I/O7 (input/output pins): I/O pins function as mask data at the falling edge of $\overline{\text{RAS}}$ (in mask write mode). Data is written only to high I/O pins. Data on low I/O pins are masked and internal data are retained. After that, they function as input/output pins as those of a standard DRAM. In block write cycle, they function as address mask data at the falling edge of $\overline{\text{CAS}}$.

$\overline{\text{DT/OE}}$ (input pin): $\overline{\text{DT/OE}}$ pin functions as $\overline{\text{DT}}$ (data transfer) pin at the falling edge of $\overline{\text{RAS}}$ and as $\overline{\text{OE}}$ (output enable) pin after that. When $\overline{\text{DT}}$ is low at the falling edge of $\overline{\text{RAS}}$, this cycle becomes a transfer cycle. When $\overline{\text{DT}}$ is high at the falling edge of $\overline{\text{RAS}}$, RAM and SAM operate independently.

SC (input pin): SC is a basic SAM clock. In a serial read cycle, data outputs from an SI/O pin synchronously with the rising edge of SC. In a serial write cycle, data on an SI/O pin at the rising edge of SC is fetched into the SAM data register.

$\overline{\text{SE}}$ (input pin): $\overline{\text{SE}}$ pin activates SAM. When $\overline{\text{SE}}$ is high, SI/O is in the high impedance state in serial read cycle and data on SI/O is not fetched into the SAM data register in serial write cycle. $\overline{\text{SE}}$ can be used as a mask for serial write because internal pointer is incremented at the rising edge of SC.

SI/O0 – SI/O7 (input/output pins): SI/Os are input/output pins in SAM. Direction of input/output is determined by the previous transfer cycle. When it was a read transfer cycle, SI/O outputs data. When it was a pseudo transfer cycle or write transfer cycle, SI/O inputs data.

DSF (input pin): DSF is a special function data input flag pin. It is set to high at the falling edge of $\overline{\text{RAS}}$ when new functions such as color register read/write, split transfer, and flash write, are used. DSF is set to high at the falling edge of $\overline{\text{CAS}}$ when block write is executed.

QSF (output pin): QSF outputs data of address A7 in SAM. QSF is switched from low to high by accessing address 127 in SAM and from high to low by accessing 255 address in SAM.

Operation of HM538123B

RAM Read Cycle ($\overline{DT/OE}$ high, \overline{CAS} high and DSF low at the falling edge of \overline{RAS} , DSF low at the falling edge of \overline{CAS})

Row address is entered at the \overline{RAS} falling edge and column address at the \overline{CAS} falling edge to the device as in standard DRAM. Then, when \overline{WE} is high and $\overline{DT/OE}$ is low while \overline{CAS} is low, the selected address data outputs through I/O pin. At the falling edge of \overline{RAS} , $\overline{DT/OE}$ and \overline{CAS} become high to distinguish RAM read cycle from transfer cycle and CBR refresh cycle. Address access time (t_{AA}) and \overline{RAS} to column address delay time (t_{RAD}) specifications are added to enable high-speed page mode.

RAM Write Cycle (Early Write, Delayed Write, Read-Modify-Write) ($\overline{DT/OE}$ high, \overline{CAS} high and DSF low at the falling edge of \overline{RAS} , DSF low at the falling edge of \overline{CAS})

- Normal Mode Write Cycle (\overline{WE} high at the falling edge of \overline{RAS})
When \overline{CAS} and \overline{WE} are set low after driving \overline{RAS} low, a write cycle is executed and I/O data is written in the selected addresses. When all 8 I/Os are written, \overline{WE} should be high at the falling edge of \overline{RAS} to distinguish normal mode from mask write mode.
If \overline{WE} is set low before the \overline{CAS} falling edge, this cycle becomes an early write cycle and I/O becomes in high impedance. Data is entered at the \overline{CAS} falling edge.
If \overline{WE} is set low after the \overline{CAS} falling edge, this cycle becomes a delayed write cycle. Data is input at the \overline{WE} falling. I/O does not become high impedance in this cycle, so data should be entered with \overline{OE} in high.
If \overline{WE} is set low after t_{cWD} (min) and t_{AWD} (min) after the \overline{CAS} falling edge, this cycle becomes a read-modify-write cycle and enables read/write at the same address in one cycle. In this cycle also, to avoid I/O contention, data should be input after reading data and driving \overline{OE} high.
- Mask Write Mode (\overline{WE} low at the falling edge of \overline{RAS})
If \overline{WE} is set low at the falling edge of \overline{RAS} , the cycle becomes a mask write mode which writes only to selected I/O. Whether or not an I/O is written depends on I/O level (mask data) at the falling edge of \overline{RAS} . Then the data is written in high I/O pins and masked in low ones and internal data is retained. This mask data is effective during the \overline{RAS} cycle. So, in high-speed page mode, the mask data is retained during the page access.

HM538123B Series

High-Speed Page Mode Cycle ($\overline{DT}/\overline{OE}$ high, \overline{CAS} high and DSF low at the falling edge of \overline{RAS})

High-speed page mode cycle reads/writes the data of the same row address at high speed by toggling \overline{CAS} while \overline{RAS} is low. Its cycle time is one third of the random read/write cycle. In this cycle, read, write, and block write cycles can be mixed. Note that address access time (t_{AA}), \overline{RAS} to column address delay time (t_{RAD}), and access time from \overline{CAS} precharge (t_{ACP}) are added. In one \overline{RAS} cycle, 256-word memory cells of the same row address can be accessed. It is necessary to specify access frequency within $t_{RASP} \text{ max (100 } \mu\text{s)}$.

Color Register Set/Read Cycle (\overline{CAS} high, $\overline{DT}/\overline{OE}$ high, \overline{WE} high and DSF high at the falling edge of \overline{RAS})

In color register set cycle, color data is set to the internal color register used in flash write cycle or block write cycle. 8 bits of internal color register are provided at each I/O. This register is composed of static circuits, so once it is set, it retains the data until reset. Color register set cycle is just as same as the usual write cycle except that DSF is set high at the falling edge of \overline{RAS} , and read, early write and delayed write cycle can be executed. In this cycle, HM538123B refreshes the row address fetched at the falling edge of \overline{RAS} .

Flash Write Cycle (\overline{CAS} high, $\overline{DT}/\overline{OE}$ high, \overline{WE} low and DSF high at the falling edge of \overline{RAS})

In a flash write cycle, a row of data (256-word \times 8-bit) is cleared to 0 or 1 at each I/O according to the data of color register mentioned before. It is also necessary to mask I/O in this cycle. When \overline{CAS} and $\overline{DT}/\overline{OE}$ is set high, \overline{WE} is low, and DSF is high at the falling edge of \overline{RAS} , this cycle starts. Then, the row address to clear is given to row address and mask data is given to I/O. Mask data is as same as that of a RAM write cycle. High I/O is cleared, low I/O is not cleared and the internal data is retained. Cycle time is the same as those of RAM read/write cycles, so all bits can be cleared in 1/256 of the usual cycle time. (See figure 1.)

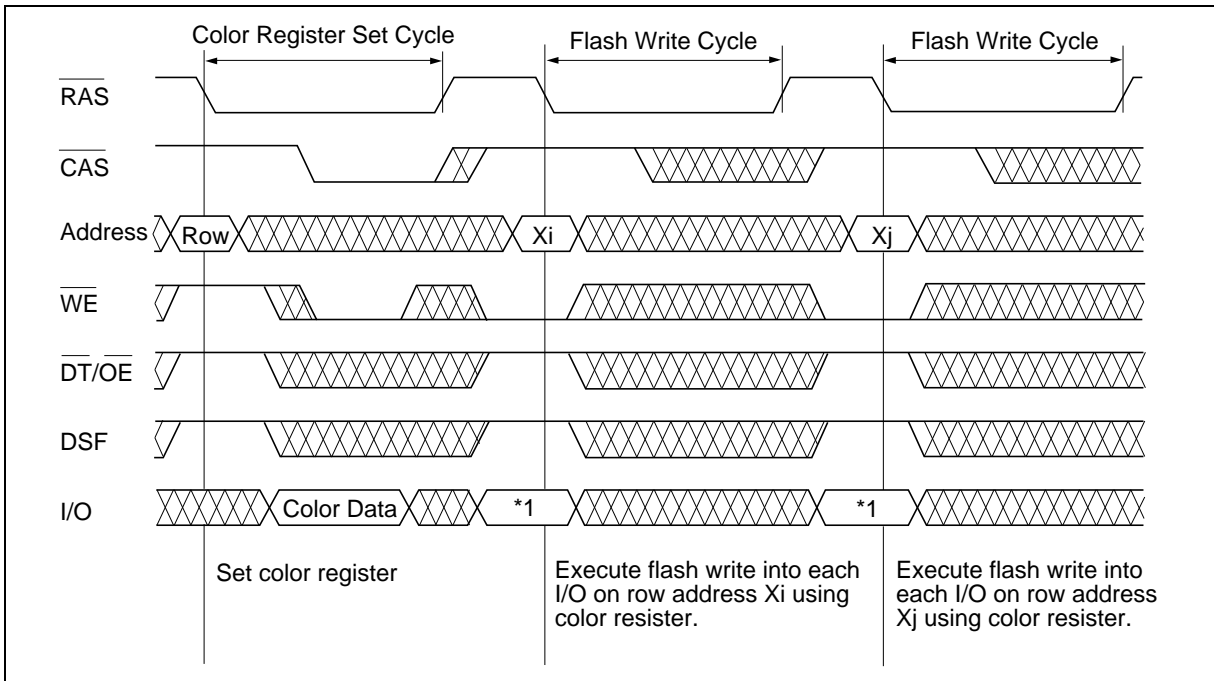

Figure 1 Use of Flash Write

Block Write Cycle (\overline{CAS} high, $\overline{DT/OE}$ high and DSF low at the falling edge of \overline{RAS} , DSF high at the falling edge of \overline{CAS})

In a block write cycle, 4 columns of data (4-word \times 8-bit) is cleared to 0 or 1 at each I/O according to the data of color register. Column addresses A0 and A1 are disregarded. The data on I/Os and addresses can be masked. I/O level at the falling edge of \overline{CAS} determines the address to be cleared. (See figure 2.)

- Normal Mode Block Write Cycle (\overline{WE} high at the falling edge of \overline{RAS})
The data on 8 I/Os are all cleared when \overline{WE} is high at the falling edge of \overline{RAS} .
- Mask Block Write Mode (\overline{WE} low at the falling edge of \overline{RAS})
When \overline{WE} is low at the falling edge of \overline{RAS} , HM538123B starts mask block write mode to clear the data on an optional I/O. The mask data is the same as that of a RAM write cycle. High I/O is cleared, low I/O is not cleared and the internal data is retained. The mask data is available in the \overline{RAS} cycle. In page mode block write cycle, the mask data is retained during the page access.

HM538123B Series

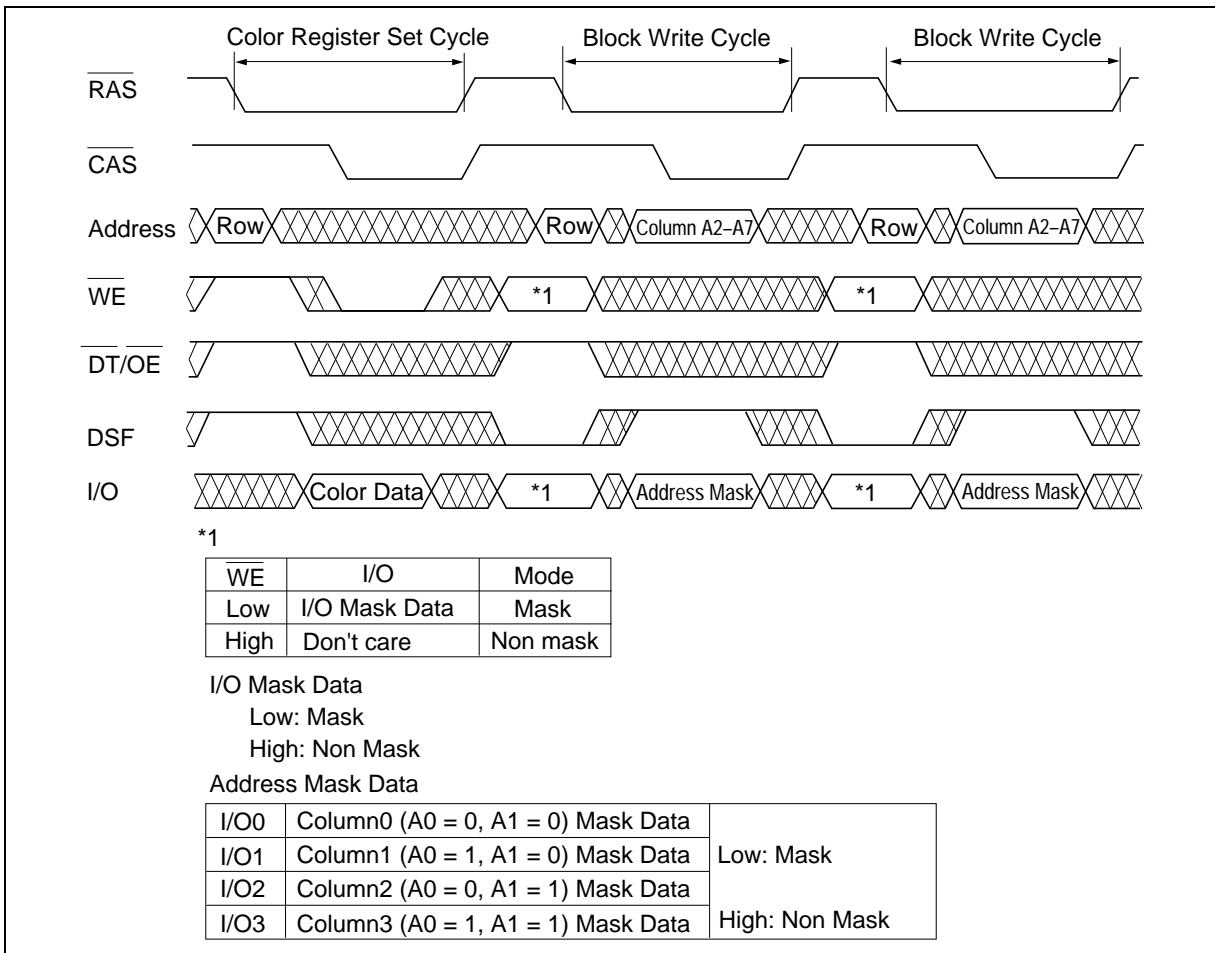

Figure 2 Use of Block Write

Transfer Operation

The HM538123B provides the read transfer cycle, split read transfer cycle, pseudo transfer cycle, write transfer cycle and split write transfer cycle as data transfer cycles. These transfer cycles are set by driving $\overline{\text{CAS}}$ high and $\overline{\text{DT/OE}}$ low at the falling edge of $\overline{\text{RAS}}$. They have following functions:

- (1) Transfer data between row address and SAM data register (except for pseudo transfer cycle)
 - Read transfer cycle and split read transfer cycle: RAM to SAM
 - Write transfer cycle and split write transfer cycle: SAM to RAM
- (2) Determine SI/O state (except for split read transfer cycle and split write transfer cycle)
 - Read transfer cycle: SI/O output
 - Pseudo transfer cycle and write transfer cycle: SI/O input
- (3) Determine first SAM address to access after transferring at column address (SAM start address).

SAM start address must be determined by read transfer cycle or pseudo transfer cycle (split transfer cycle isn't available) before SAM access, after power on, and determined for each transfer cycle.

Read Transfer Cycle ($\overline{\text{CAS}}$ high, $\overline{\text{DT/OE}}$ low, $\overline{\text{WE}}$ high and DSF low at the falling edge of $\overline{\text{RAS}}$)

This cycle becomes read transfer cycle by driving $\overline{\text{DT/OE}}$ low, $\overline{\text{WE}}$ high and DSF low at the falling edge of $\overline{\text{RAS}}$. The row address data ($256 \times 8\text{-bit}$) determined by this cycle is transferred to SAM data register synchronously at the rising edge of $\overline{\text{DT/OE}}$. After the rising edge of $\overline{\text{DT/OE}}$, the new address data outputs from SAM start address determined by column address. In read transfer cycle, $\overline{\text{DT/OE}}$ must be risen to transfer data from RAM to SAM.

This cycle can access SAM even during transfer (real time read transfer). In this case, the timing t_{SDD} (min) specified between the last SAM access before transfer and $\overline{\text{DT/OE}}$ rising edge and t_{SDH} (min) specified between the first SAM access and $\overline{\text{DT/OE}}$ rising edge must be satisfied. (See figure 3.)

When read transfer cycle is executed, SI/O becomes output state by first SAM access. Input must be set high impedance before t_{SZS} (min) of the first SAM access to avoid data contention.

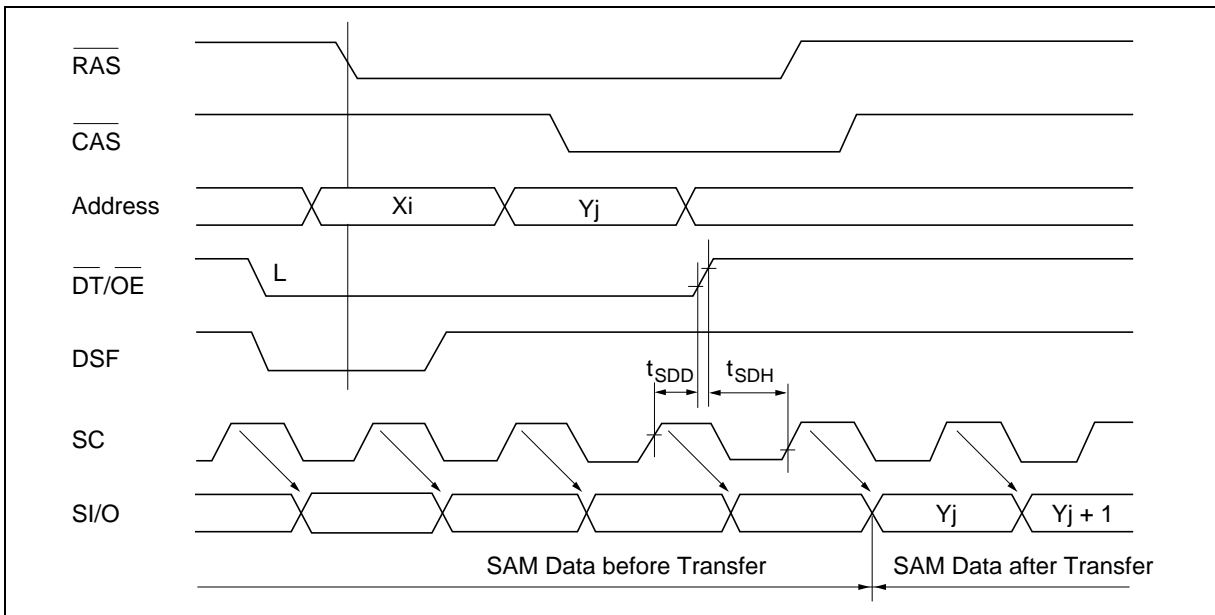

Figure 3 Real Time Read Transfer

Pseudo Transfer Cycle ($\overline{\text{CAS}}$ high, $\overline{\text{DT/OE}}$ low, $\overline{\text{WE}}$ low, $\overline{\text{SE}}$ high and DSF low at the falling edge of $\overline{\text{RAS}}$)

Pseudo transfer cycle switches SI/O to input state and set SAM start address without data transfer to RAM.

This cycle starts when $\overline{\text{CAS}}$ is high, $\overline{\text{DT/OE}}$ low, $\overline{\text{WE}}$ low, $\overline{\text{SE}}$ high and DSF low at the falling edge of $\overline{\text{RAS}}$. Data should be input to SI/O later than t_{SID} (min) after $\overline{\text{RAS}}$ becomes low to avoid data contention. SAM access becomes enabled after t_{SRD} (min) after $\overline{\text{RAS}}$ becomes high. In this cycle, SAM access is inhibited during $\overline{\text{RAS}}$ low, therefore, SC must not be risen.

HM538123B Series

Write Transfer Cycle ($\overline{\text{CAS}}$ high, $\overline{\text{DT}}/\overline{\text{OE}}$ low, $\overline{\text{WE}}$ low, $\overline{\text{SE}}$ low and DSF low at the falling edge of $\overline{\text{RAS}}$)

Write transfer cycle can transfer a row of data input by serial write cycle to RAM. The row address of data transferred into RAM is determined by the address at the falling edge of $\overline{\text{RAS}}$. The column address is specified as the first address for serial write after terminating this cycle. Also in this cycle, SAM access becomes enabled after t_{SRD} (min) after $\overline{\text{RAS}}$ becomes high. SAM access is inhibited during $\overline{\text{RAS}}$ low. In this period, SC must not be risen. Data transferred to SAM by read transfer cycle or split read transfer cycle can be written to other addresses of RAM by write transfer cycle. However, the address to write data must be the same as that of the read transfer cycle or the split read transfer cycle (row address AX8). Figure 4 shows the example of row bit data transfer. In case AX8 is 0, data cannot be transferred RAM address within the range of 100000000 to 111111111. Same as the case of AX8 = 1.

Split Read Transfer Cycle ($\overline{\text{CAS}}$ high, $\overline{\text{DT}}/\overline{\text{OE}}$ low, $\overline{\text{WE}}$ high and DSF high at the falling edge of $\overline{\text{RAS}}$)

To execute a continuous serial read by real time read transfer, HM538123B must satisfy SC and $\overline{\text{DT}}/\overline{\text{OE}}$ timings and requires an external circuit to detect SAM last address. Split read transfer cycle makes it possible to execute a continuous serial read without the above timing limitation. Figure 5 shows the block diagram for a split transfer. SAM data register (DR) consists of 2 split buffers, whose organizations are 128-word \times 8-bit each. Let us suppose that data is read from upper data register DR1 (The row address AX8 is 0 and SAM address A7 is 1.). When split read transfer is executed setting row address AX8 0 and SAM start addresses A0 to A6, 128-word \times 8-bit data are transferred from RAM to the lower data register DR0 (SAM address A7 is 0) automatically. After data are read from data register DR1, data start to be read from SAM start addresses of data register DR0. If the next split read transfer isn't executed while data are read from data register DR0, data start to be read from SAM start address 0 of DR1 after data are read from data register DR0. If split read transfer is executed setting row address AX8 1 and SAM start addresses A0 to A6 while data are read from data register DR1, 128-word \times 8-bit data are transferred to data register DR2. After data are read from data register DR1, data start to be read from SAM start addresses of data register DR2. If the next split read transfer isn't executed while data is read from data register DR2, data start to be read from SAM start address 0 of data register DR3 after data are read from data register DR2. In this time, SAM data is the one transferred to data register DR3 finally while row address AX8 is 1. In split read data transfer, the SAM start address A7 is automatically set in the data register which isn't used.

The data on SAM address A7, which will be accessed next, outputs to QSF, QSF is switched from low to high by accessing SAM last address 127 and from high to low by accessing address 255.

Split read transfer cycle is set when $\overline{\text{CAS}}$ is high, $\overline{\text{DT}}/\overline{\text{OE}}$ is low, $\overline{\text{WE}}$ is high and DSF is high at the falling edge of $\overline{\text{RAS}}$. The cycle can be executed asynchronously with SC. However, HM538123B must be satisfied t_{STS} (min) timing specified between SC rising and $\overline{\text{RAS}}$ falling. SAM start address must be accessed, satisfying t_{RST} (min), t_{CST} (min) and t_{AST} (min) timings specified between $\overline{\text{RAS}}$ or $\overline{\text{CAS}}$ falling and column address. (See figure 6.)

In split read transfer, SI/O isn't switched to output state. Therefore, read transfer must be executed to switch SI/O to output state when the previous transfer cycle is pseudo transfer or write transfer cycle.

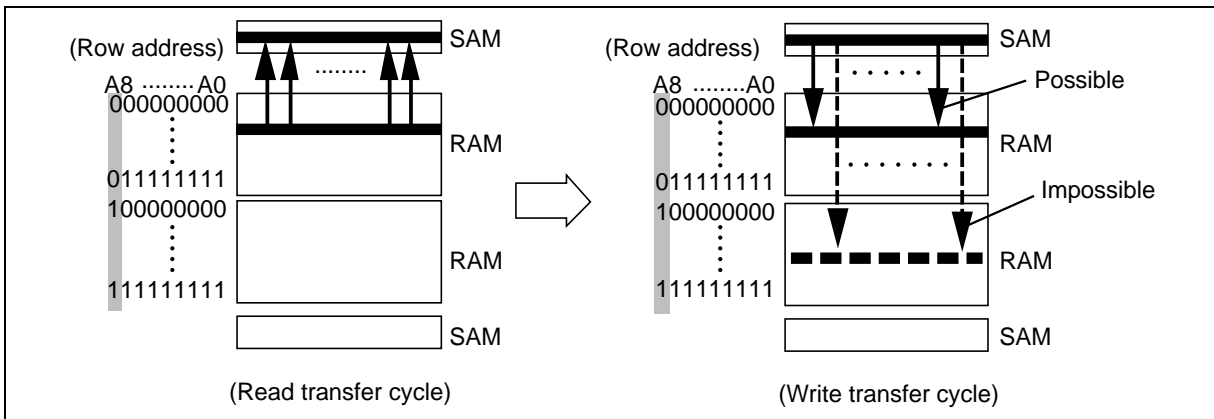

Figure 4 Example of Row Bit Data Transfer

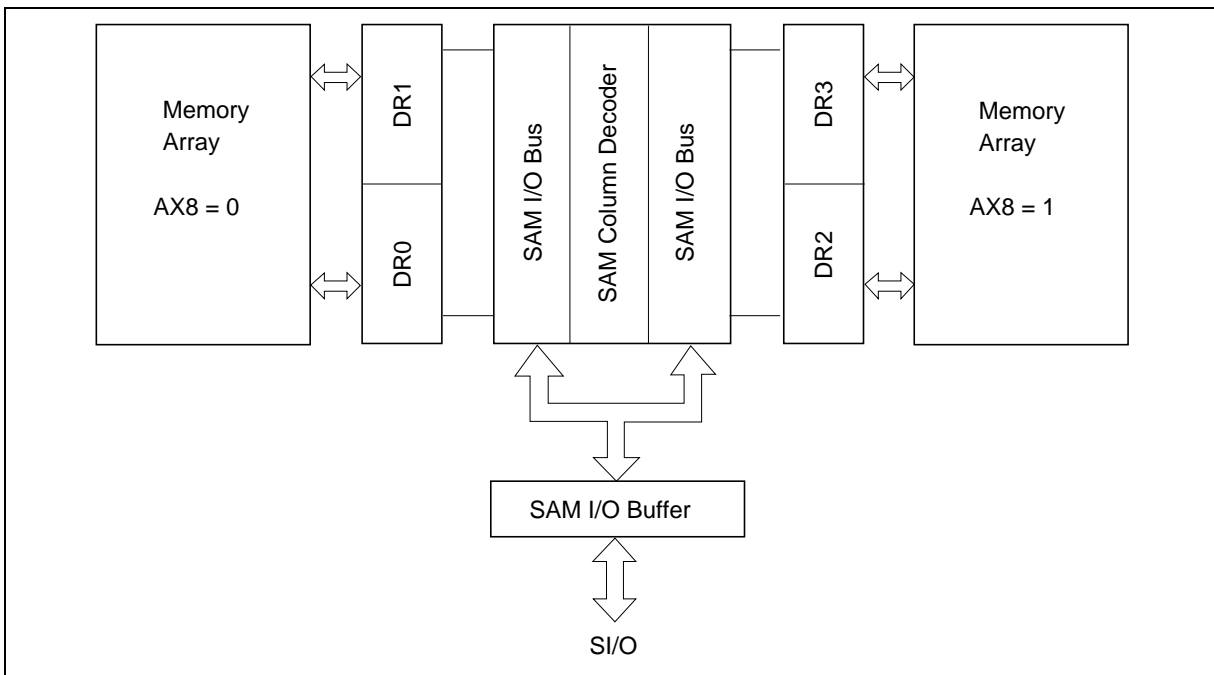

Figure 5 Block Diagram for Split Transfer

Split Write Transfer Cycle ($\overline{\text{CAS}}$ high, $\overline{\text{DT/OE}}$ low, $\overline{\text{WE}}$ low and DSF high at the falling edge of $\overline{\text{RAS}}$)

A continuous serial write cannot be executed because accessing SAM is inhibited during $\overline{\text{RAS}}$ low in write transfer. Split write transfer cycle makes it possible. In this cycle, t_{STS} (min), t_{RST} (min), t_{CST} (min) and t_{AST} (min) timings must be satisfied like split read transfer cycle. And it is impossible to switch SI/O to input state in this cycle. If SI/O is in output state, pseudo transfer cycle should be executed to switch SI/O into input state. Data transferred to SAM by read transfer cycle or split read transfer cycle can be written to other addresses of RAM by split write transfer cycle. However, pseudo transfer cycle must be executed before split write transfer cycle. And the MSB of row address (AX8) to write data must be the same as that of the read transfer cycle or the split read transfer cycle.

HM538123B Series

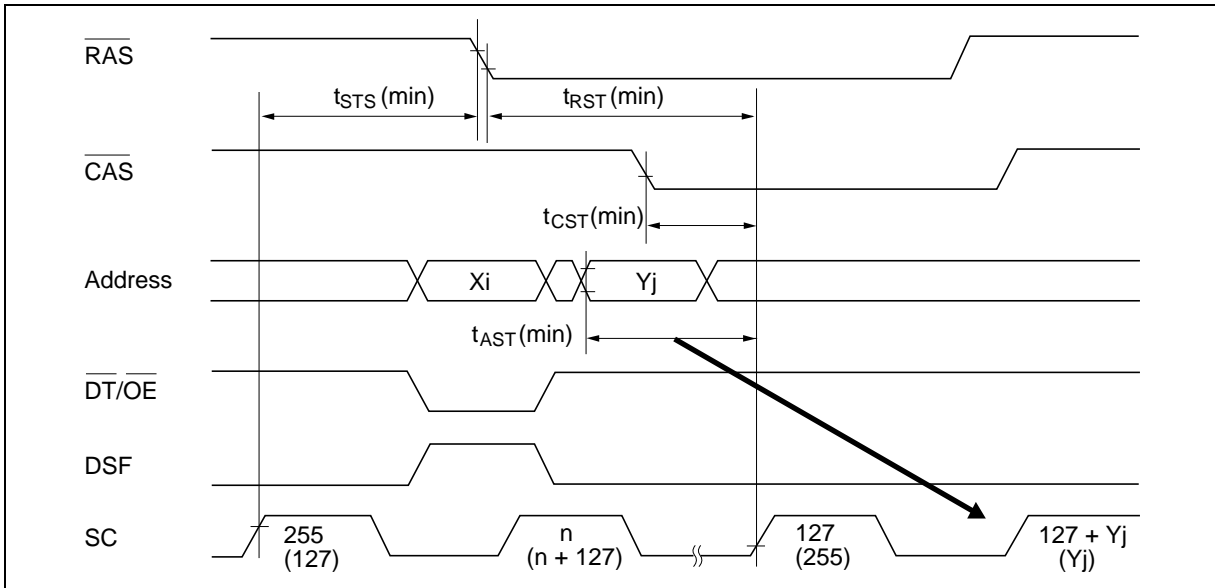

Figure 6 Limitation in Split Transfer

SAM Port Operation

Serial Read Cycle

SAM port is in read mode when the previous data transfer cycle is read transfer cycle. Access is synchronized with SC rising, and SAM data is output from SI/O. When \overline{SE} is set high, SI/O becomes high impedance, and the internal pointer is incremented by the SC rising. After indicating the last address (address 255), the internal pointer indicates address 0 at the next access.

Serial Write Cycle

If previous data transfer cycle is pseudo transfer cycle or write transfer cycle, SAM port goes into write mode. In this cycle, SI/O data is fetched into data register at the SC rising edge like in the serial read cycle. If \overline{SE} is high, SI/O data isn't fetched into data register. Internal pointer is incremented by the SC rising, so \overline{SE} high can be used as mask data for SAM. After indicating the last address (address 255), the internal pointer indicates address 0 at the next access.

Refresh

RAM Refresh

RAM, which is composed of dynamic circuits, requires refresh to retain data. Refresh is executed by accessing all 512 row addresses within 8 ms. There are three refresh cycles: (1) $\overline{\text{RAS}}$ -only refresh cycle, (2) $\overline{\text{CAS}}$ -before- $\overline{\text{RAS}}$ (CBR) refresh cycle, and (3) Hidden refresh cycle. Besides them, the cycles which activate $\overline{\text{RAS}}$ such as read/write cycles or transfer cycles can refresh the row address. Therefore, no refresh cycle is required when all row addresses are accessed within 8 ms.

- (1) $\overline{\text{RAS}}$ -Only Refresh Cycle: $\overline{\text{RAS}}$ -only refresh cycle is executed by activating only $\overline{\text{RAS}}$ cycle with $\overline{\text{CAS}}$ fixed to high after inputting the row address (= refresh address) from external circuits. To distinguish this cycle from data transfer cycle, $\overline{\text{DT}}/\overline{\text{OE}}$ must be high at the falling edge of $\overline{\text{RAS}}$.
- (2) CBR Refresh Cycle: CBR refresh cycle is set by activating $\overline{\text{CAS}}$ before $\overline{\text{RAS}}$. In this cycle, refresh address needs not to be input through external circuits because it is input through an internal refresh counter. In this cycle, output is in high impedance and power dissipation is lowered because $\overline{\text{CAS}}$ circuits don't operate.
- (3) Hidden Refresh Cycle: Hidden refresh cycle executes CBR refresh with the data output by reactivating $\overline{\text{RAS}}$ when $\overline{\text{DT}}/\overline{\text{OE}}$ and $\overline{\text{CAS}}$ keep low in normal RAM read cycles.

SAM Refresh

SAM parts (data register, shift register and selector), organized as fully static circuitry, require no refresh.

Absolute Maximum Ratings

Parameter	Symbol	Value	Unit
Terminal voltage ¹⁾	V_T	-1.0 to +7.0	V
Power supply voltage ¹⁾	V_{CC}	-0.5 to +7.0	V
Short circuit output current	I_{out}	50	mA
Power dissipation	P_T	1.0	W
Operating temperature	T_{opr}	0 to +70	°C
Storage temperature	T_{stg}	-55 to +125	°C

Note: 1. Relative to V_{SS} .

HM538123B Series

Recommended DC Operating Conditions (Ta = 0 to +70°C)

Parameter	Symbol	Min	Typ	Max	Unit
Supply voltage ¹	V _{CC}	4.5	5.0	5.5	V
Input high voltage ¹	V _{IH}	2.4	—	6.5	V
Input low voltage ¹	V _{IL}	-0.5 ²	—	0.8	V

- Notes: 1. All voltages referred to V_{SS}
 2. -3.0 V for pulse width ≤ 10 ns

DC Characteristics (Ta = 0 to +70°C, V_{CC} = 5 V ± 10%, V_{SS} = 0 V)

		HM538123B								Test Conditions		
		-6		-7		-8		-10				
Parameter	Symbol	Min	Max	Min	Max	Min	Max	Min	Max	Unit	RAM Port	SAM Port
Operating current	I _{CC1}	—	75	—	70	—	60	—	55	mA	$\overline{\text{RAS}}$, $\overline{\text{CAS}}$ cycling t _{RC} = Min	SC = V _{IL} , $\overline{\text{SE}}$ = V _{IH}
	I _{CC7}	—	125	—	120	—	100	—	95	mA		$\overline{\text{SE}}$ = V _{IL} , SC cycling t _{SCC} = Min
Standby current	I _{CC2}	—	7	—	7	—	7	—	7	mA	$\overline{\text{RAS}}$, CAS = V _{IH}	SC = V _{IL} , SE = V _{IH}
	I _{CC8}	—	50	—	50	—	40	—	40	mA		$\overline{\text{SE}}$ = V _{IL} , SC cycling t _{SCC} = Min
$\overline{\text{RAS}}$ -only refresh current	I _{CC3}	—	75	—	70	—	60	—	55	mA	$\overline{\text{RAS}}$ cycling CAS = V _{IH} t _{RC} = Min	SC = V _{IL} , SE = V _{IH}
	I _{CC9}	—	125	—	120	—	100	—	95	mA		$\overline{\text{SE}}$ = V _{IL} , SC cycling t _{SCC} = Min
Page mode current	I _{CC4}	—	80	—	80	—	70	—	65	mA	$\overline{\text{CAS}}$ cycling RAS = V _{IL} t _{PC} = Min	SC = V _{IL} , $\overline{\text{SE}}$ = V _{IH}
	I _{CC10}	—	130	—	130	—	110	—	105	mA		$\overline{\text{SE}}$ = V _{IL} , SC cycling t _{SCC} = Min

HM538123B Series

DC Characteristics (Ta = 0 to +70°C, V_{CC} = 5 V ± 10%, V_{SS} = 0 V) (cont)

Parameter	Symbol	HM538123B								Unit	Test Conditions	
		-6		-7		-8		-10			RAM Port	SAM Port
		Min	Max	Min	Max	Min	Max	Min	Max			
CAS-before-RAS refresh current	I _{CC5}	—	50	—	45	—	40	—	35	mA	$\overline{\text{RAS}}$ cycling t _{RC} = Min	SC = V _{IL} , SE = V _{IH}
	I _{CC11}	—	100	—	95	—	80	—	75	mA		SE = V _{IL} , SC cycling t _{SCC} = Min
Data transfer current	I _{CC6}	—	80	—	75	—	65	—	60	mA	$\overline{\text{RAS}}$, $\overline{\text{CAS}}$ cycling t _{RC} = Min	SC = V _{IL} , SE = V _{IH}
	I _{CC12}	—	130	—	125	—	105	—	100	mA		SE = V _{IL} , SC cycling t _{SCC} = Min
Input leakage current	I _{LI}	-10	10	-10	10	-10	10	-10	10	μA		
Output leakage current	I _{LO}	-10	10	-10	10	-10	10	-10	10	μA		
Output high voltage	V _{OH}	2.4	—	2.4	—	2.4	—	2.4	—	V	I _{OH} = -2 mA	
Output low voltage	V _{OL}	—	0.4	—	0.4	—	0.4	—	0.4	V	I _{OL} = 4.2 mA	

Notes: 1. I_{CC} depends on output loading condition when the device is selected. I_{CC} max is specified at the output open condition.

2. Address can be changed once while $\overline{\text{RAS}}$ is low and $\overline{\text{CAS}}$ is high.

Capacitance (Ta = 25°C, V_{CC} = 5 V, f = 1 MHz, Bias: Clock, I/O = V_{CC}, address = V_{SS})

Parameter	Symbol	Min	Typ	Max	Unit
Address	C _{I1}	—	—	5	pF
Clock	C _{I2}	—	—	5	pF
I/O, SI/O, QSF	C _{I/O}	—	—	7	pF

HM538123B Series

AC Characteristics ($T_a = 0$ to $+70^\circ\text{C}$, $V_{cc} = 5\text{ V} \pm 10\%$, $V_{ss} = 0\text{ V}$)^{*1,*16}

Test Conditions

- Input rise and fall time : 5 ns
- Output load : See figures
- Input pulse levels: V_{ss} to 3.0 V
- Input timing reference levels : 0.8 V, 2.4 V
- Output timing reference levels : 0.8 V, 2.0 V

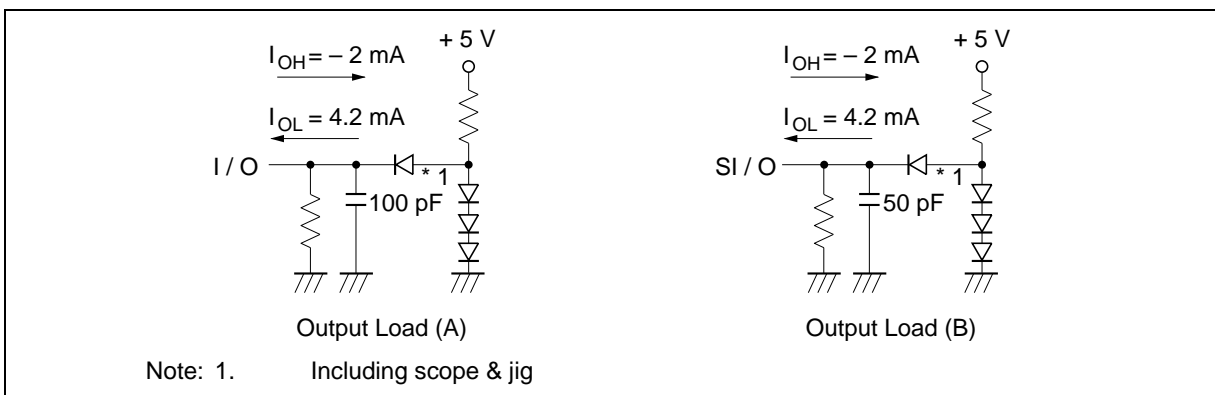

HM538123B Series

Common Parameter

Parameter	Symbol	HM538123B								Unit	Notes
		-6		-7		-8		-10			
		Min	Max	Min	Max	Min	Max	Min	Max		
Random read or write cycle time	t_{RC}	125	—	135	—	150	—	180	—	ns	
\overline{RAS} precharge time	t_{RP}	55	—	55	—	60	—	70	—	ns	
\overline{RAS} pulse width	t_{RAS}	60	10000	70	10000	80	10000	100	10000	ns	
\overline{CAS} pulse width	t_{CAS}	20	—	20	—	20	—	25	—	ns	
Row address setup time	t_{ASR}	0	—	0	—	0	—	0	—	ns	
Row address hold time	t_{RAH}	10	—	10	—	10	—	10	—	ns	
Column address setup time	t_{ASC}	0	—	0	—	0	—	0	—	ns	
Column address hold time	t_{CAH}	15	—	15	—	15	—	15	—	ns	
\overline{RAS} to \overline{CAS} delay time	t_{RCD}	20	40	20	50	20	60	20	75	ns	2
\overline{RAS} hold time referenced to \overline{CAS}	t_{RSH}	20	—	20	—	20	—	25	—	ns	
\overline{CAS} hold time referenced to \overline{RAS}	t_{CSH}	60	—	70	—	80	—	100	—	ns	
\overline{CAS} to \overline{RAS} precharge time	t_{CRP}	10	—	10	—	10	—	10	—	ns	
Transition time (rise to fall)	t_T	3	50	3	50	3	50	3	50	ns	3
Refresh period	t_{REF}	—	8	—	8	—	8	—	8	ms	
\overline{DT} to \overline{RAS} setup time	t_{DTS}	0	—	0	—	0	—	0	—	ns	
\overline{DT} to \overline{RAS} hold time	t_{DTH}	10	—	10	—	10	—	10	—	ns	
DSF to \overline{RAS} setup time	t_{FSR}	0	—	0	—	0	—	0	—	ns	
DSF to \overline{RAS} hold time	t_{RFH}	10	—	10	—	10	—	10	—	ns	
DSF to \overline{CAS} setup time	t_{FSC}	0	—	0	—	0	—	0	—	ns	
DSF to \overline{CAS} hold time	t_{CFH}	15	—	15	—	15	—	15	—	ns	
Data-in to \overline{CAS} delay time	t_{DZC}	0	—	0	—	0	—	0	—	ns	4
Data-in to \overline{OE} delay time	t_{DZO}	0	—	0	—	0	—	0	—	ns	4
Output buffer turn-off delay referred to \overline{CAS}	t_{OFF1}	—	20	—	20	—	20	—	20	ns	5
Output buffer turn-off delay referred to \overline{OE}	t_{OFF2}	—	20	—	20	—	20	—	20	ns	5

HM538123B Series

Read Cycle (RAM), Page Mode Read Cycle

Parameter	Symbol	HM538123B								Uni t	Note s
		-6		-7		-8		-10			
		Min	Max	Min	Max	Min	Max	Min	Max		
Access time from $\overline{\text{RAS}}$	t_{RAC}	—	60	—	70	—	80	—	100	ns	6, 7
Access time from $\overline{\text{CAS}}$	t_{CAC}	—	20	—	20	—	20	—	25	ns	7, 8
Access time from $\overline{\text{OE}}$	t_{OAC}	—	20	—	20	—	20	—	25	ns	7
Address access time	t_{AA}	—	35	—	35	—	40	—	45	ns	7, 9
Read command setup time	t_{RCS}	0	—	0	—	0	—	0	—	ns	
Read command hold time	t_{RCH}	0	—	0	—	0	—	0	—	ns	10
Read command hold time referenced to $\overline{\text{RAS}}$	t_{RRH}	10	—	10	—	10	—	10	—	ns	10
$\overline{\text{RAS}}$ to column address delay time	t_{RAD}	15	25	15	35	15	40	15	55	ns	2
Column address to $\overline{\text{RAS}}$ lead time	t_{RAL}	35	—	35	—	40	—	45	—	ns	
Column address to $\overline{\text{CAS}}$ lead time	t_{CAL}	35	—	35	—	40	—	45	—	ns	
Page mode cycle time	t_{PC}	45	—	45	—	50	—	55	—	ns	
$\overline{\text{CAS}}$ precharge time	t_{CP}	10	—	10	—	10	—	10	—	ns	
Access time from $\overline{\text{CAS}}$ precharge	t_{ACP}	—	40	—	40	—	45	—	50	ns	
Page mode $\overline{\text{RAS}}$ pulse width	t_{RASP}	60	100000	70	100000	80	100000	100	100000	ns	

HM538123B Series

Write Cycle (RAM), Page Mode Write Cycle, Color Register Set Cycle

Parameter	Symbol	HM538123B								Units	Notes
		-6		-7		-8		-10			
		Min	Max	Min	Max	Min	Max	Min	Max		
Write command setup time	t_{WCS}	0	—	0	—	0	—	0	—	ns	11
Write command hold time	t_{WCH}	15	—	15	—	15	—	15	—	ns	
Write command pulse width	t_{WP}	15	—	15	—	15	—	15	—	ns	
Write command to \overline{RAS} lead time	t_{RWL}	20	—	20	—	20	—	20	—	ns	
Write command to \overline{CAS} lead time	t_{CWL}	20	—	20	—	20	—	20	—	ns	
Data-in setup time	t_{DS}	0	—	0	—	0	—	0	—	ns	12
Data-in hold time	t_{DH}	15	—	15	—	15	—	15	—	ns	12
\overline{WE} to \overline{RAS} setup time	t_{WS}	0	—	0	—	0	—	0	—	ns	
\overline{WE} to \overline{RAS} hold time	t_{WH}	10	—	10	—	10	—	10	—	ns	
Mask data to \overline{RAS} setup time	t_{MS}	0	—	0	—	0	—	0	—	ns	
Mask data to \overline{RAS} hold time	t_{MH}	10	—	10	—	10	—	10	—	ns	
\overline{OE} hold time referred to \overline{WE}	t_{OEH}	20	—	20	—	20	—	20	—	ns	
Page mode cycle time	t_{PC}	45	—	45	—	50	—	55	—	ns	
\overline{CAS} precharge time	t_{CP}	10	—	10	—	10	—	10	—	ns	
\overline{CAS} to data-in delay time	t_{CDD}	20	—	20	—	20	—	20	—	ns	13
Page mode \overline{RAS} pulse width	t_{RASP}	60	100000	70	100000	80	100000	100	100000	ns	

HM538123B Series

Read-Modify-Write Cycle

Parameter	Symbol	HM538123B								Uni t	Note s
		-6		-7		-8		-10			
		Min	Max	Min	Max	Min	Max	Min	Max		
Read-modify-write cycle time	t_{RWC}	175	—	185	—	200	—	230	—	ns	
\overline{RAS} pulse width (read-modify-write cycle)	t_{RWS}	110	10000	120	10000	130	10000	150	10000	ns	
\overline{CAS} to \overline{WE} delay time	t_{CWD}	45	—	45	—	45	—	50	—	ns	14
Column address to \overline{WE} delay time	t_{AWD}	60	—	60	—	65	—	70	—	ns	14
\overline{OE} to data-in delay time	t_{ODD}	20	—	20	—	20	—	20	—	ns	12
Access time from \overline{RAS}	t_{RAC}	—	60	—	70	—	80	—	100	ns	6, 7
Access time from \overline{CAS}	t_{CAC}	—	20	—	20	—	20	—	25	ns	7, 8
Access time from \overline{OE}	t_{OAC}	—	20	—	20	—	20	—	25	ns	7
Address access time	t_{AA}	—	35	—	35	—	40	—	45	ns	7, 9
\overline{RAS} to column address delay time	t_{RAD}	15	25	15	35	15	40	15	55	ns	
Read command setup time	t_{RCS}	0	—	0	—	0	—	0	—	ns	
Write command to \overline{RAS} lead time	t_{RWL}	20	—	20	—	20	—	20	—	ns	
Write command to \overline{CAS} lead time	t_{CWL}	20	—	20	—	20	—	20	—	ns	
Write command pulse width	t_{WP}	15	—	15	—	15	—	15	—	ns	
Data-in setup time	t_{DS}	0	—	0	—	0	—	0	—	ns	12
Data-in hold time	t_{DH}	15	—	15	—	15	—	15	—	ns	12
\overline{OE} hold time referred to \overline{WE}	t_{OEH}	20	—	20	—	20	—	20	—	ns	

Refresh Cycle

Parameter	Symbol	HM538123B								Uni t	Note s
		-6		-7		-8		-10			
		Min	Max	Min	Max	Min	Max	Min	Max		
\overline{CAS} setup time (\overline{CAS} -before- \overline{RAS} refresh)	t_{CSR}	10	—	10	—	10	—	10	—	ns	
\overline{CAS} hold time (\overline{CAS} -before- \overline{RAS} refresh)	t_{CHR}	10	—	10	—	10	—	10	—	ns	
\overline{RAS} precharge to \overline{CAS} hold time	t_{RPC}	10	—	10	—	10	—	10	—	ns	

Flash Write Cycle, Block Write Cycle

		HM538123B									
		-6		-7		-8		-10			
Parameter	Symbol	Min	Max	Min	Max	Min	Max	Min	Max	Unit	Notes
$\overline{\text{CAS}}$ to data-in delay time	t_{CDD}	20	—	20	—	20	—	20	—	ns	13
$\overline{\text{OE}}$ to data-in delay time	t_{ODD}	20	—	20	—	20	—	20	—	ns	13

Read Transfer Cycle

		HM538123B									
		-6		-7		-8		-10			
Parameter	Symbol	Min	Max	Min	Max	Min	Max	Min	Max	Unit	Notes
$\overline{\text{DT}}$ hold time referenced to $\overline{\text{RAS}}$	t_{RDH}	50	10000	60	10000	65	10000	80	10000	ns	
$\overline{\text{DT}}$ hold time referenced to $\overline{\text{CAS}}$	t_{CDH}	20	—	20	—	20	—	25	—	ns	
$\overline{\text{DT}}$ hold time referenced to column address	t_{ADH}	25	—	25	—	30	—	30	—	ns	
$\overline{\text{DT}}$ precharge time	t_{DTP}	20	—	20	—	20	—	30	—	ns	
$\overline{\text{DT}}$ to $\overline{\text{RAS}}$ delay time	t_{DRD}	65	—	65	—	70	—	80	—	ns	
SC to $\overline{\text{RAS}}$ setup time	t_{SRS}	25	—	25	—	30	—	30	—	ns	
1st SC to $\overline{\text{RAS}}$ hold time	t_{SRH}	60	—	70	—	80	—	100	—	ns	
1st SC to $\overline{\text{CAS}}$ hold time	t_{SCH}	25	—	25	—	25	—	25	—	ns	
1st SC to column address hold time	t_{SAH}	40	—	40	—	45	—	50	—	ns	
Last SC to $\overline{\text{DT}}$ delay time	t_{SDD}	5	—	5	—	5	—	5	—	ns	
Last SC to $\overline{\text{DT}}$ delay time	t_{SDD2}	25	—	25	—	25	—	25	—	ns	17
1st SC to $\overline{\text{DT}}$ hold time	t_{SDH}	10	—	10	—	15	—	15	—	ns	
$\overline{\text{RAS}}$ to QSF delay time	t_{RQD}	—	65	—	70	—	75	—	85	ns	15
$\overline{\text{CAS}}$ to QSF delay time	t_{CQD}	—	35	—	35	—	40	—	40	ns	15
$\overline{\text{DT}}$ to QSF delay time	t_{DQD}	—	35	—	35	—	35	—	35	ns	15
QSF hold time referred to $\overline{\text{RAS}}$	t_{RQH}	20	—	20	—	20	—	25	—	ns	
QSF hold time referred to $\overline{\text{CAS}}$	t_{CQH}	5	—	5	—	5	—	5	—	ns	
QSF hold time referred to $\overline{\text{DT}}$	t_{DQH}	5	—	5	—	5	—	5	—	ns	
Serial data-in to 1st SC delay time	t_{SZS}	0	—	0	—	0	—	0	—	ns	
Serial clock cycle time	t_{SCC}	25	—	25	—	30	—	30	—	ns	

HM538123B Series

Read Transfer Cycle (cont)

Parameter	Symbol	HM538123B								Uni t	Note s
		-6		-7		-8		-10			
		Min	Max	Min	Max	Min	Max	Min	Max		
SC pulse width	t_{SC}	5	—	5	—	10	—	10	—	ns	
SC precharge time	t_{SCP}	10	—	10	—	10	—	10	—	ns	
SC access time	t_{SCA}	—	20	—	22	—	25	—	25	ns	15
Serial data-out hold time	t_{SOH}	5	—	5	—	5	—	5	—	ns	
Serial data-in setup time	t_{SIS}	0	—	0	—	0	—	0	—	ns	
Serial data-in hold time	t_{SIH}	15	—	15	—	15	—	15	—	ns	
\overline{RAS} to column address delay time	t_{RAD}	15	25	15	35	15	40	15	55	ns	
Column address to \overline{RAS} lead time	t_{RAL}	35	—	35	—	40	—	45	—	ns	
\overline{RAS} precharge to \overline{DT} high hold time	t_{DTHH}	10	—	10	—	10	—	10	—	ns	

HM538123B Series

Pseudo Transfer Cycle, Write Transfer Cycle

Parameter	Symbol	HM538123B								Uni t	Note s
		-6		-7		-8		-10			
		Min	Max	Min	Max	Min	Max	Min	Max		
\overline{SE} setup time referred to \overline{RAS}	t_{ES}	0	—	0	—	0	—	0	—	ns	
\overline{SE} hold time referred to \overline{RAS}	t_{EH}	10	—	10	—	10	—	10	—	ns	
SC setup time referred to \overline{RAS}	t_{SRS}	25	—	25	—	30	—	30	—	ns	
\overline{RAS} to SC delay time	t_{SRD}	20	—	20	—	25	—	25	—	ns	
Serial output buffer turn-off time referred to \overline{RAS}	t_{SRZ}	10	40	10	40	10	45	10	50	ns	
\overline{RAS} to serial data-in delay time	t_{SID}	40	—	40	—	45	—	50	—	ns	
\overline{RAS} to QSF delay time	t_{RQD}	—	65	—	70	—	75	—	85	ns	15
\overline{CAS} to QSF delay time	t_{COD}	—	35	—	35	—	40	—	40	ns	15
QSF hold time referred to \overline{RAS}	t_{ROH}	20	—	20	—	20	—	25	—	ns	
QSF hold time referred to \overline{CAS}	t_{CQH}	5	—	5	—	5	—	5	—	ns	
Serial clock cycle time	t_{SCC}	25	—	25	—	30	—	30	—	ns	
SC pulse width	t_{SC}	5	—	5	—	10	—	10	—	ns	
SC precharge time	t_{SCP}	10	—	10	—	10	—	10	—	ns	
SC access time	t_{SCA}	—	20	—	22	—	25	—	25	ns	15
\overline{SE} access time	t_{SEA}	—	20	—	22	—	25	—	25	ns	15
Serial data-out hold time	t_{SOH}	5	—	5	—	5	—	5	—	ns	
Serial write enable setup time	t_{SWS}	5	—	5	—	5	—	5	—	ns	
Serial data-in setup time	t_{SIS}	0	—	0	—	0	—	0	—	ns	
Serial data-in hold time	t_{SIH}	15	—	15	—	15	—	15	—	ns	

HM538123B Series

Split Read Transfer Cycle, Split Write Transfer Cycle

Parameter	Symbol	HM538123B								Uni t	Note s
		-6		-7		-8		-10			
		Min	Max	Min	Max	Min	Max	Min	Max		
Split transfer setup time	t_{STS}	20	—	20	—	20	—	25	—	ns	
Split transfer hold time referenced to \overline{RAS}	t_{RST}	60	—	70	—	80	—	100	—	ns	
Split transfer hold time referenced to \overline{CAS}	t_{CST}	20	—	20	—	20	—	25	—	ns	
Split transfer hold time referenced to column address	t_{AST}	35	—	35	—	40	—	45	—	ns	
SC to QSF delay time	t_{SQD}	—	30	—	30	—	30	—	30	ns	15
QSF hold time referred to SC	t_{SQH}	5	—	5	—	5	—	5	—	ns	
Serial clock cycle time	t_{SCC}	25	—	25	—	30	—	30	—	ns	
SC pulse width	t_{SC}	5	—	5	—	10	—	10	—	ns	
SC precharge time	t_{SCP}	10	—	10	—	10	—	10	—	ns	
SC access time	t_{SCA}	—	20	—	22	—	25	—	25	ns	15
Serial data-out hold time	t_{SOH}	5	—	5	—	5	—	5	—	ns	
Serial data-in setup time	t_{SIS}	0	—	0	—	0	—	0	—	ns	
Serial data-in hold time	t_{SIH}	15	—	15	—	15	—	15	—	ns	
\overline{RAS} to column address delay time	t_{RAD}	15	25	15	35	15	40	15	55	ns	
Column address to \overline{RAS} lead time	t_{RAL}	35	—	35	—	40	—	45	—	ns	

Serial Read Cycle, Serial Write Cycle

Parameter	Symbol	HM538123B								Uni t	Note s
		-6		-7		-8		-10			
		Min	Max	Min	Max	Min	Max	Min	Max		
Serial clock cycle time	t_{SCC}	25	—	25	—	30	—	30	—	ns	
SC pulse width	t_{SC}	5	—	5	—	10	—	10	—	ns	
SC precharge width	t_{SCP}	10	—	10	—	10	—	10	—	ns	
Access time from SC	t_{SCA}	—	20	—	22	—	25	—	25	ns	15
Access time from \overline{SE}	t_{SEA}	—	20	—	22	—	25	—	25	ns	15
Serial data-out hold time	t_{SOH}	5	—	5	—	5	—	5	—	ns	
Serial output buffer turn-off time referred to \overline{SE}	t_{SEZ}	—	20	—	20	—	20	—	20	ns	5
Serial data-in setup time	t_{SIS}	0	—	0	—	0	—	0	—	ns	
Serial data-in hold time	t_{SIH}	15	—	15	—	15	—	15	—	ns	
Serial write enable setup time	t_{SWS}	5	—	5	—	5	—	5	—	ns	
Serial write enable hold time	t_{SWH}	15	—	15	—	15	—	15	—	ns	
Serial write disable setup time	t_{SWIS}	5	—	5	—	5	—	5	—	ns	
Serial write disable hold time	t_{SWIH}	15	—	15	—	15	—	15	—	ns	

Notes: 1. AC measurements assume $t_T = 5$ ns.

2. When $t_{RCD} > t_{RCD}(\text{max})$ or $t_{RAD} > t_{RAD}(\text{max})$, access time is specified by t_{CAC} or t_{AA} .
3. $V_{IH}(\text{min})$ and $V_{IL}(\text{max})$ are reference levels for measuring timing of input signals. Transition time t_r is measured between V_{IH} and V_{IL} .
4. Data input must be floating before output buffer is turned on. In read cycle, read-modify-write cycle and delayed write cycle, either $t_{DZC}(\text{min})$ or $t_{DZO}(\text{min})$ must be satisfied.
5. $t_{OFF1}(\text{max})$, $t_{OFF2}(\text{max})$ and $t_{SEZ}(\text{max})$ are defined as the time at which the output achieves the open circuit condition ($V_{OH} - 100$ mV, $V_{OL} + 100$ mV).
6. Assume that $t_{RCD} \leq t_{RCD}(\text{max})$ and $t_{RAD} \leq t_{RAD}(\text{max})$. If t_{RCD} or t_{RAD} is greater than the maximum recommended value shown in this table, t_{RAC} exceeds the value shown.
7. Measured with a load circuit equivalent to 2 TTL loads and 100 pF.
8. When $t_{RCD} \geq t_{RCD}(\text{max})$ and $t_{RAD} \leq t_{RAD}(\text{max})$, access time is specified by t_{CAC} .
9. When $t_{RCD} \leq t_{RCD}(\text{max})$ and $t_{RAD} \geq t_{RAD}(\text{max})$, access time is specified by t_{AA} .
10. If either t_{RCH} or t_{RRH} is satisfied, operation is guaranteed.
11. When $t_{WCS} \geq t_{WCS}(\text{min})$, the cycle is an early write cycle, and I/O pins remain in an open circuit (high impedance) condition.
12. These parameters are specified by the later falling edge of \overline{CAS} or \overline{WE} .
13. Either $t_{CDD}(\text{min})$ or $t_{ODD}(\text{min})$ must be satisfied because output buffer must be turned off by \overline{CAS} or \overline{OE} prior to applying data to the device when output buffer is on.
14. When $t_{AWD} \geq t_{AWD}(\text{min})$ and $t_{CWD} \geq t_{CWD}(\text{min})$ in read-modify-write cycle, the data of the selected address outputs to an I/O pin and input data is written into the selected address. $t_{ODD}(\text{min})$ must be satisfied because output buffer must be turned off by \overline{OE} prior to applying data to the device.
15. Measured with a load circuit equivalent to 2 TTL loads and 50 pF.

HM538123B Series

16. After power-up, pause for 100 μ s or more and execute at least 8 initialization cycle (normal memory cycle or refresh cycle), then start operation.
17. After read transfer cycle, if split read transfer cycle is executed without SC access and SC address is 126 or 254, t_{SDD2} (min) must be satisfied 25 ns. Except for those cases, t_{SDD} (min) is effective and satisfied 5 ns.
18. XXX: H or L (H: V_{IH} (min) $\leq V_{\text{IN}} \leq V_{\text{IH}}$ (max), L: V_{IL} (min) $\leq V_{\text{IN}} \leq V_{\text{IL}}$ (max))
 /////: Invalid Dout

Timing Waveforms^{*18}

Read Cycle

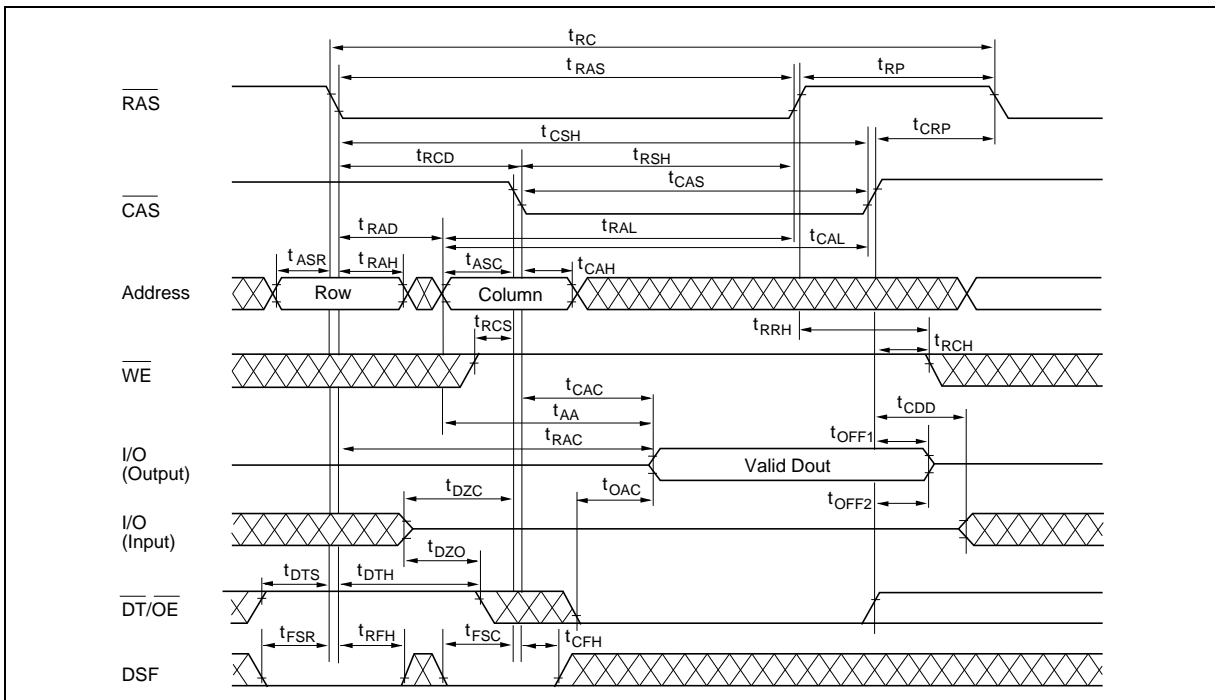

Early Write Cycle

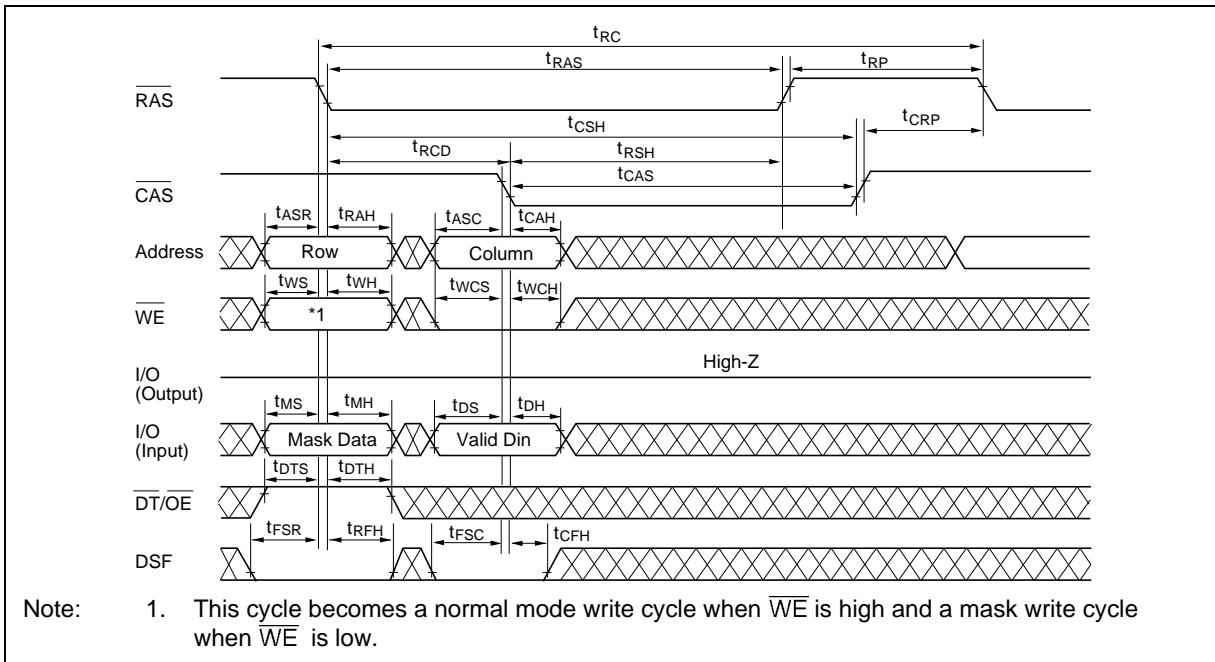

Delayed Write Cycle

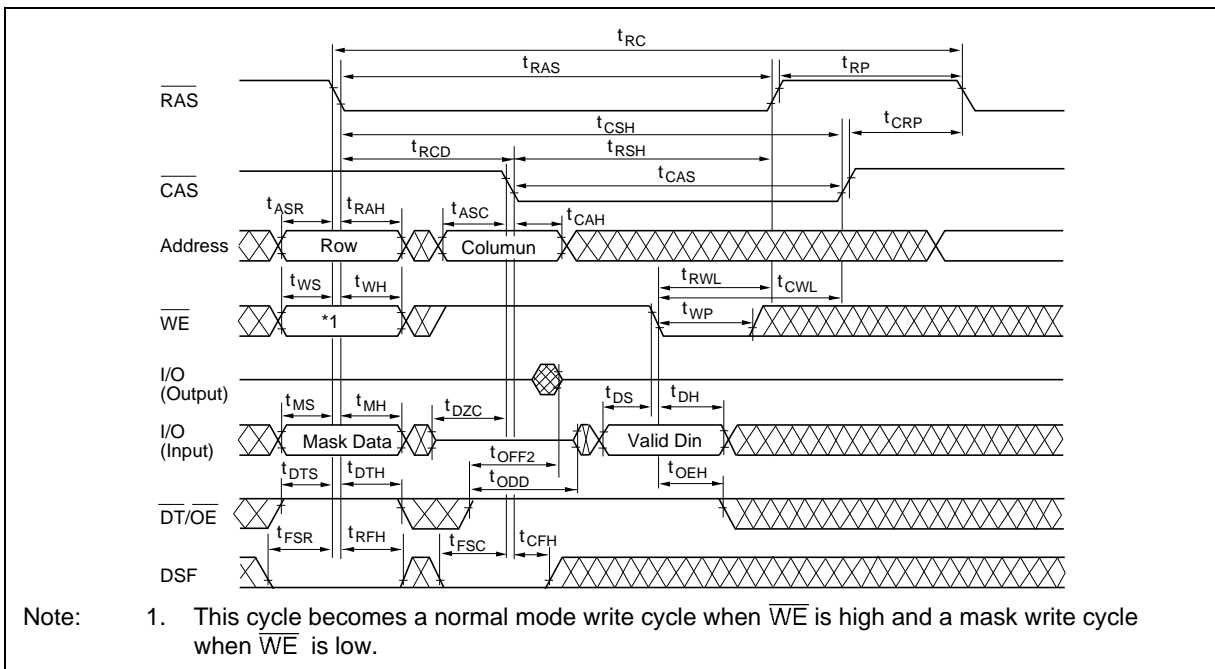

HM538123B Series

Read-Modify-Write Cycle

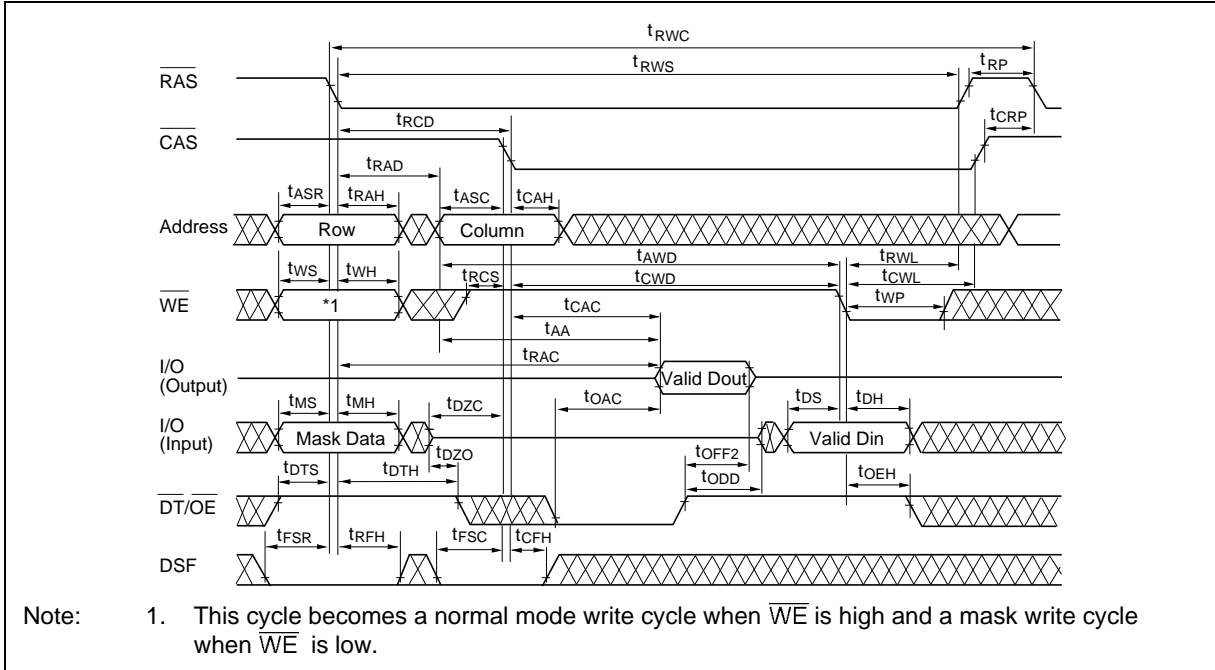

Page Mode Read Cycle

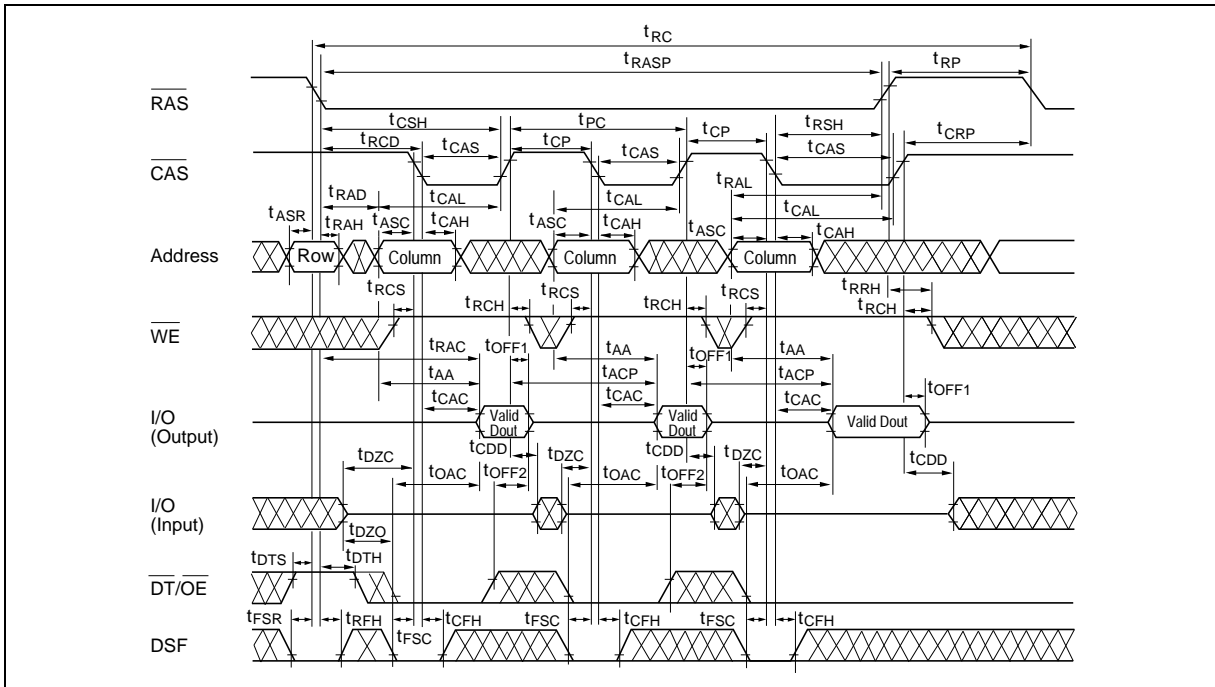

HM538123B Series

$\overline{\text{RAS}}$ -Only Refresh Cycle

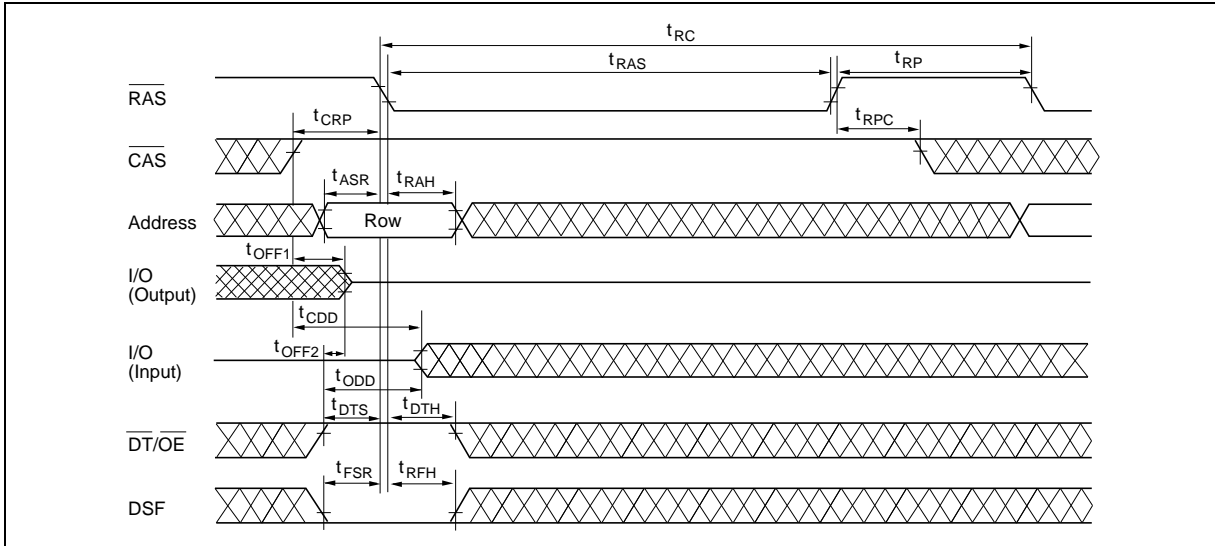

$\overline{\text{CAS}}$ -Before- $\overline{\text{RAS}}$ Refresh Cycle

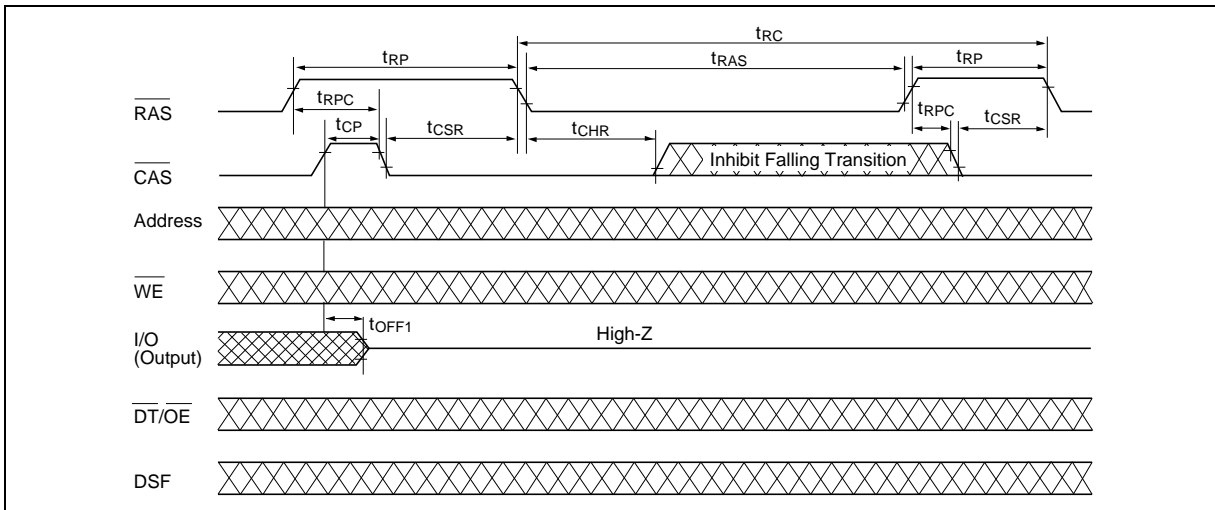

Hidden Refresh Cycle

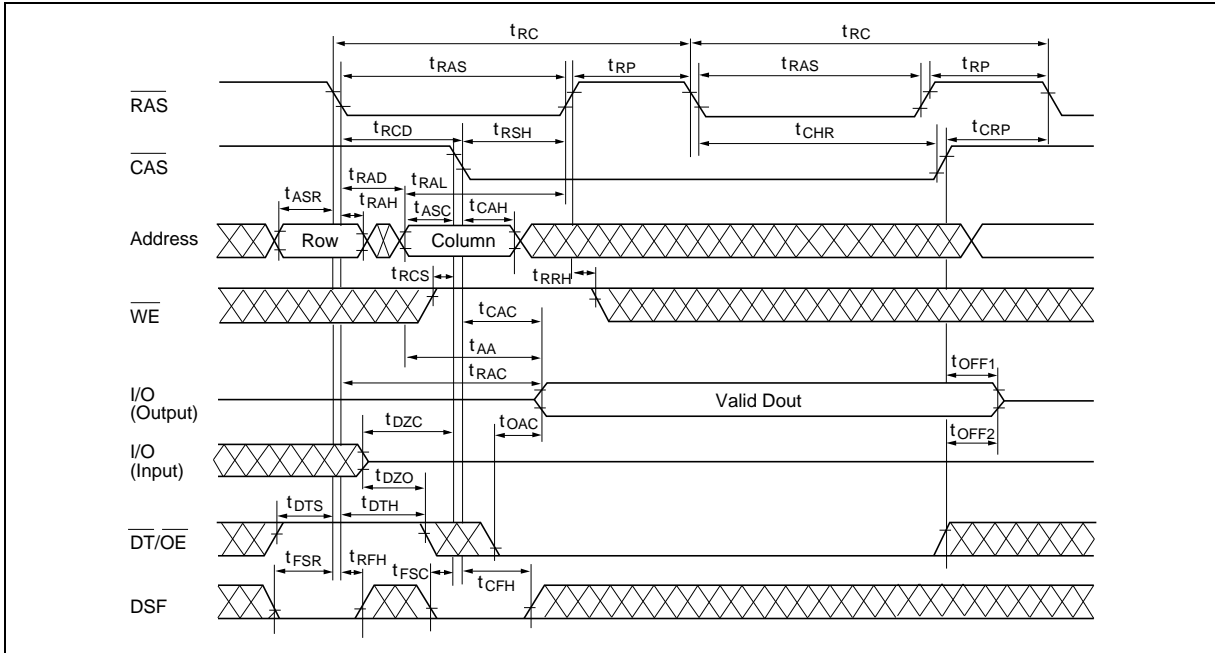

Color Register Set Cycle (Early Write)

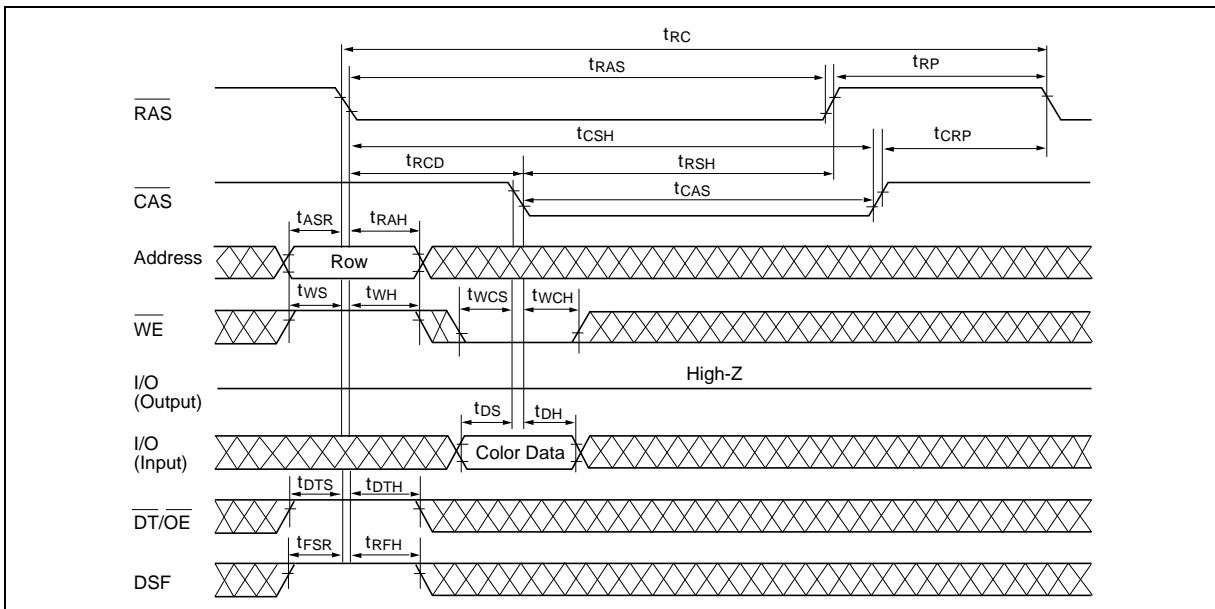

HM538123B Series

Color Register Set Cycle (Delayed Write)

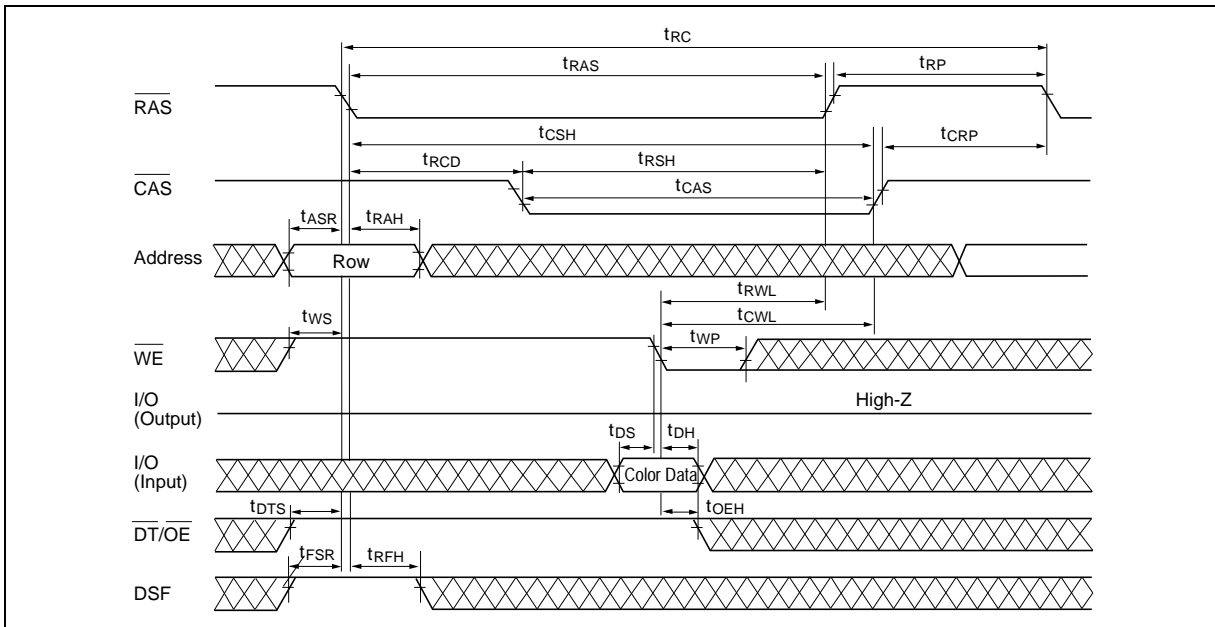

Color Register Read Cycle

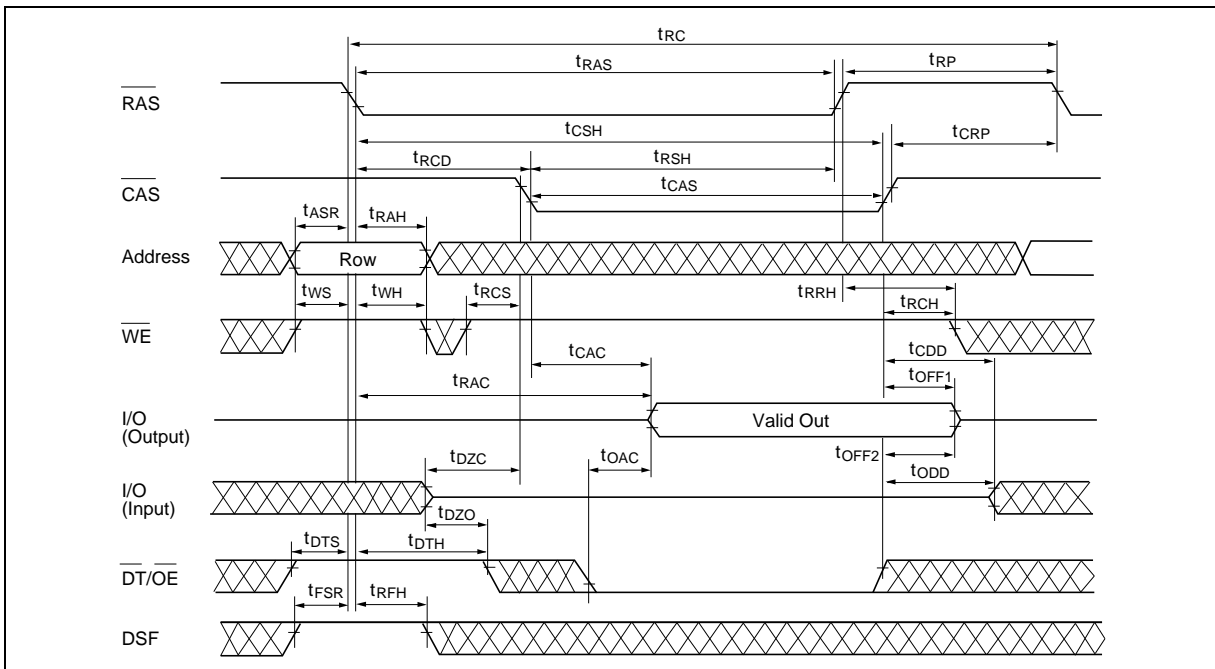

Flash Write Cycle

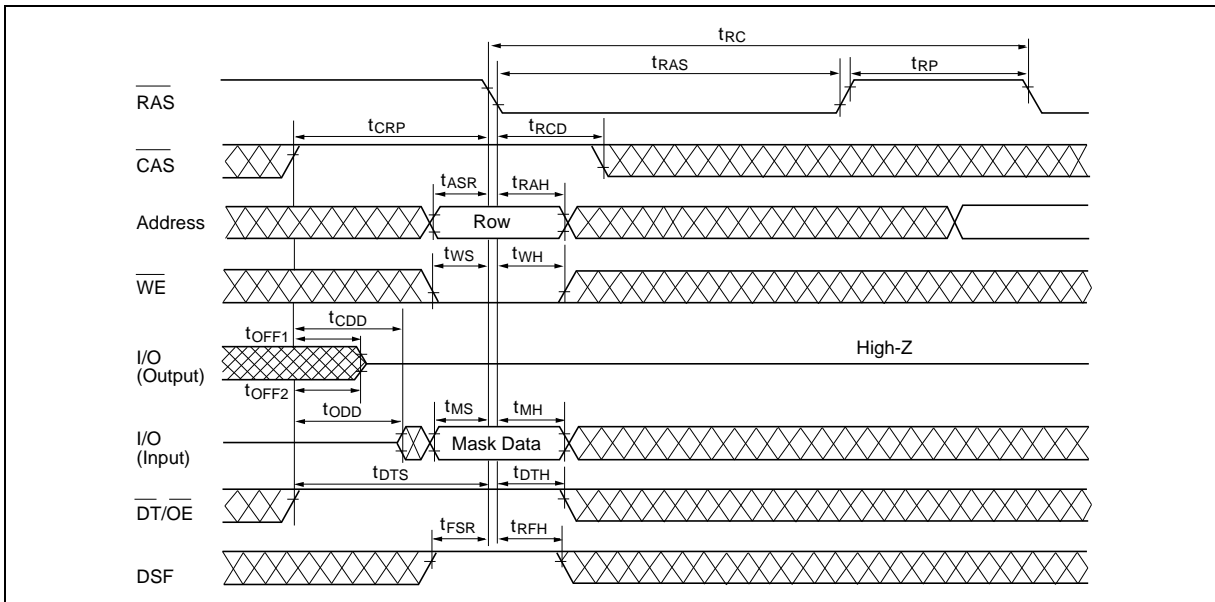

Block Write Cycle

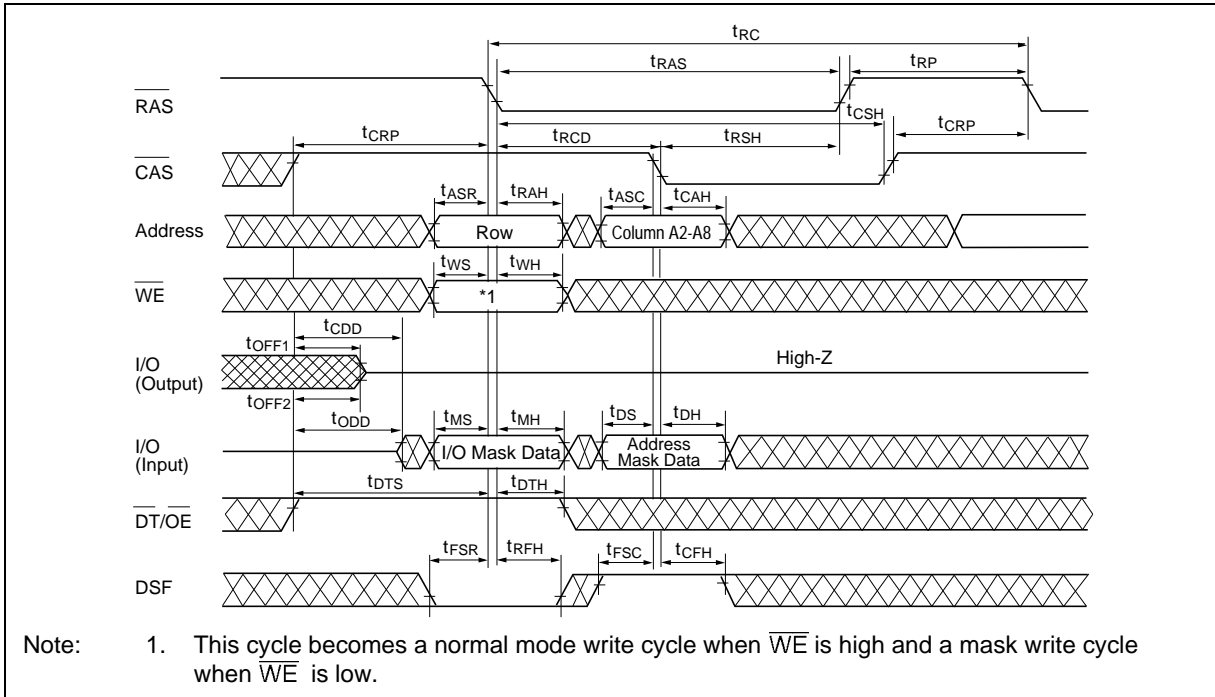

Note: 1. This cycle becomes a normal mode write cycle when \overline{WE} is high and a mask write cycle when \overline{WE} is low.

HM538123B Series

Page Mode Block Write Cycle

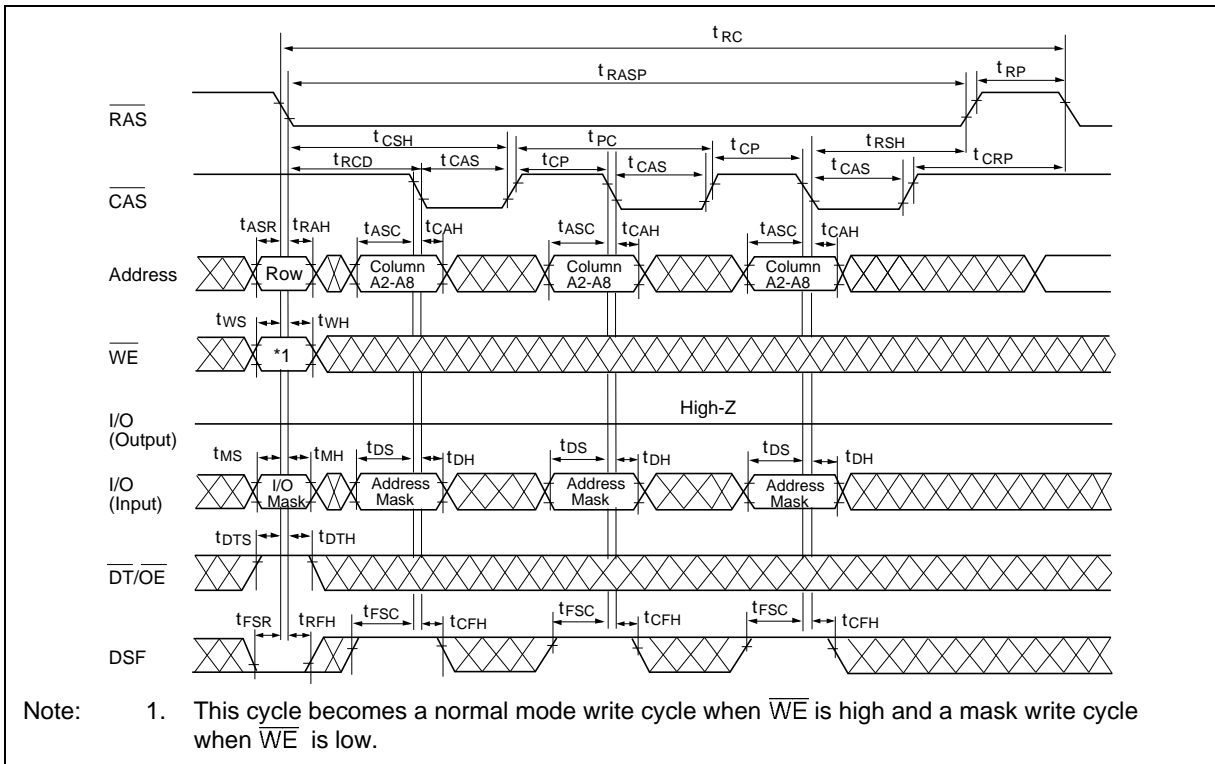

Read Transfer Cycle (1)

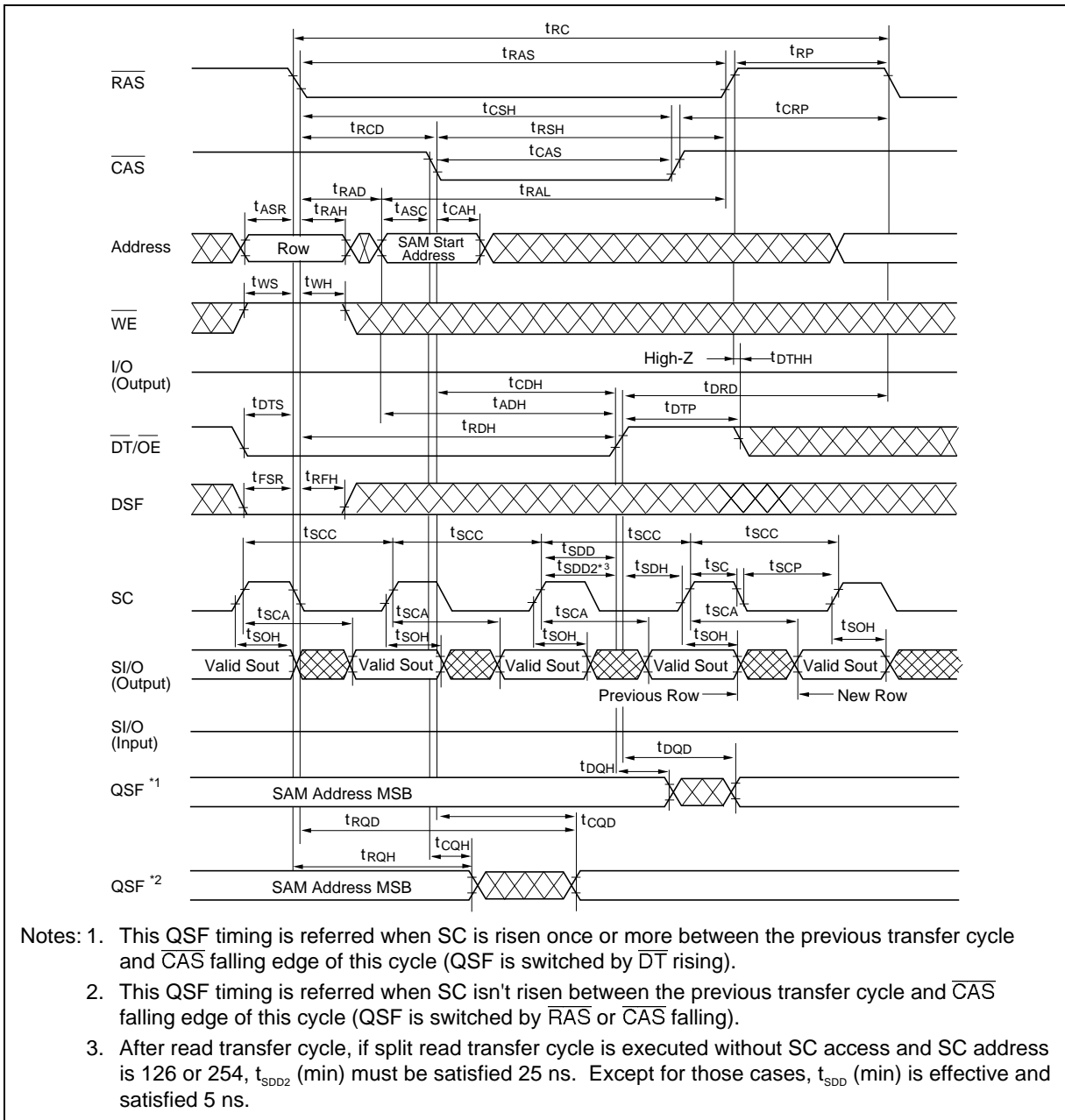

HM538123B Series

Read Transfer Cycle (2)

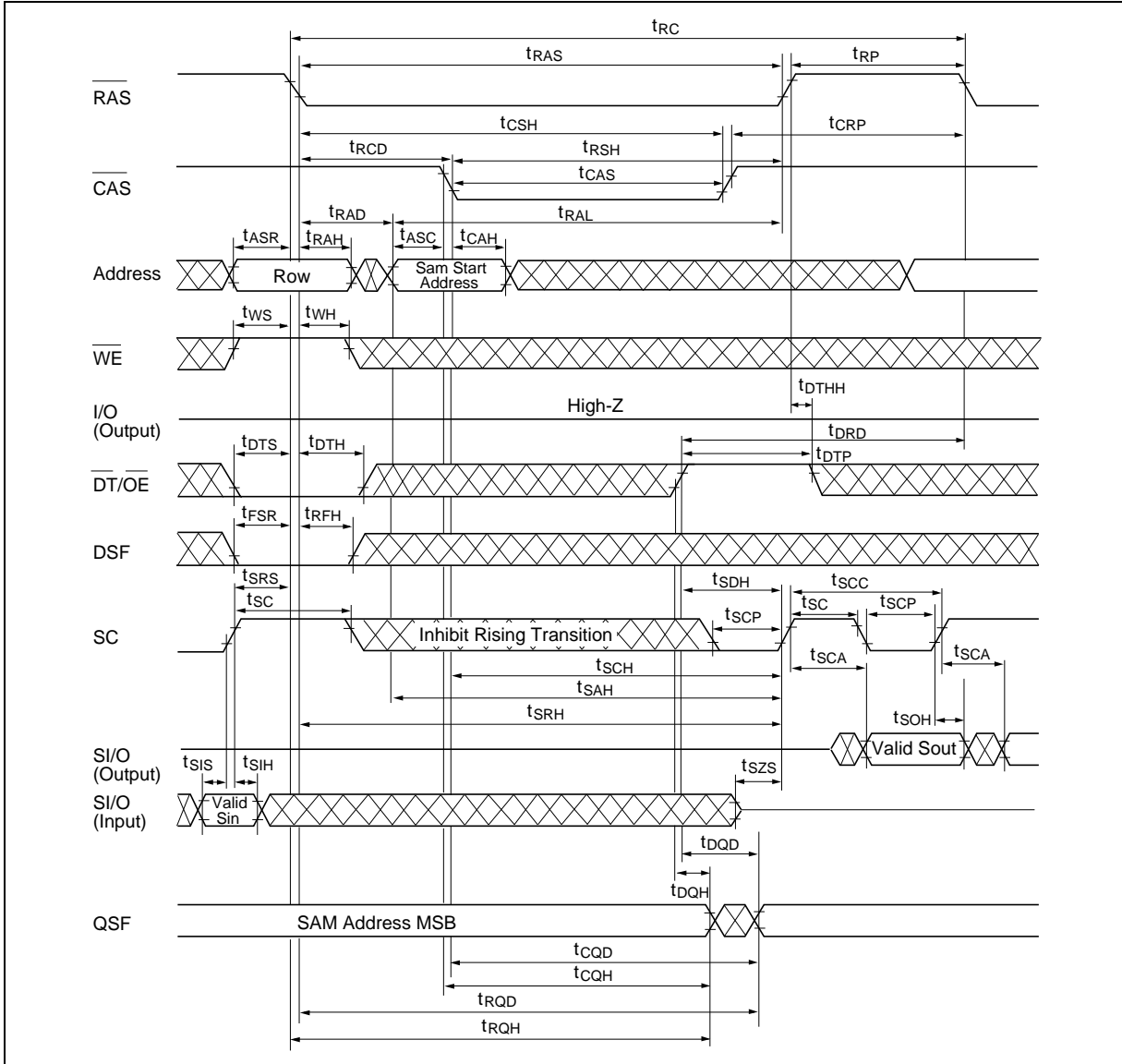

Pseudo Transfer Cycle

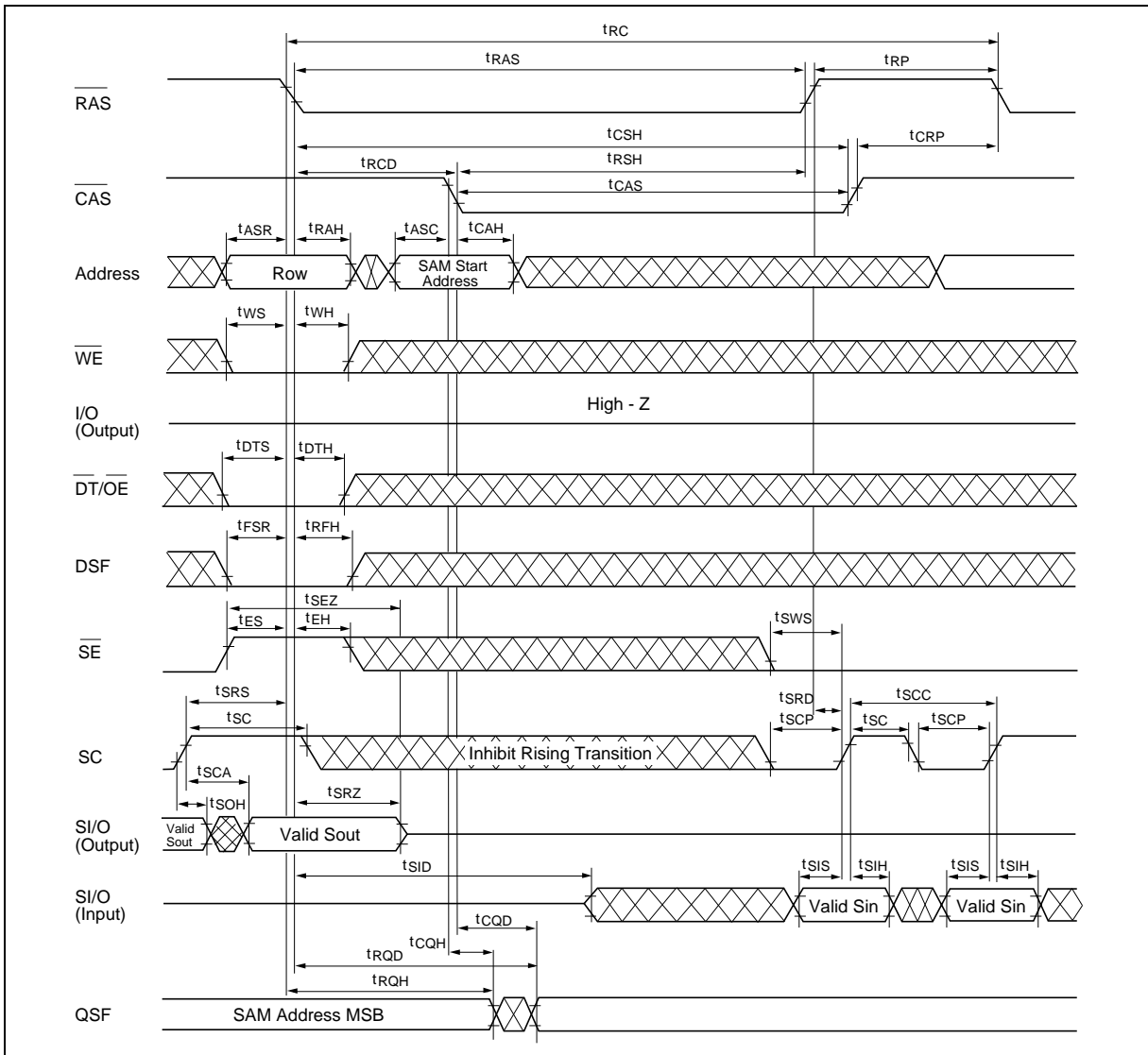

HM538123B Series

Write Transfer Cycle

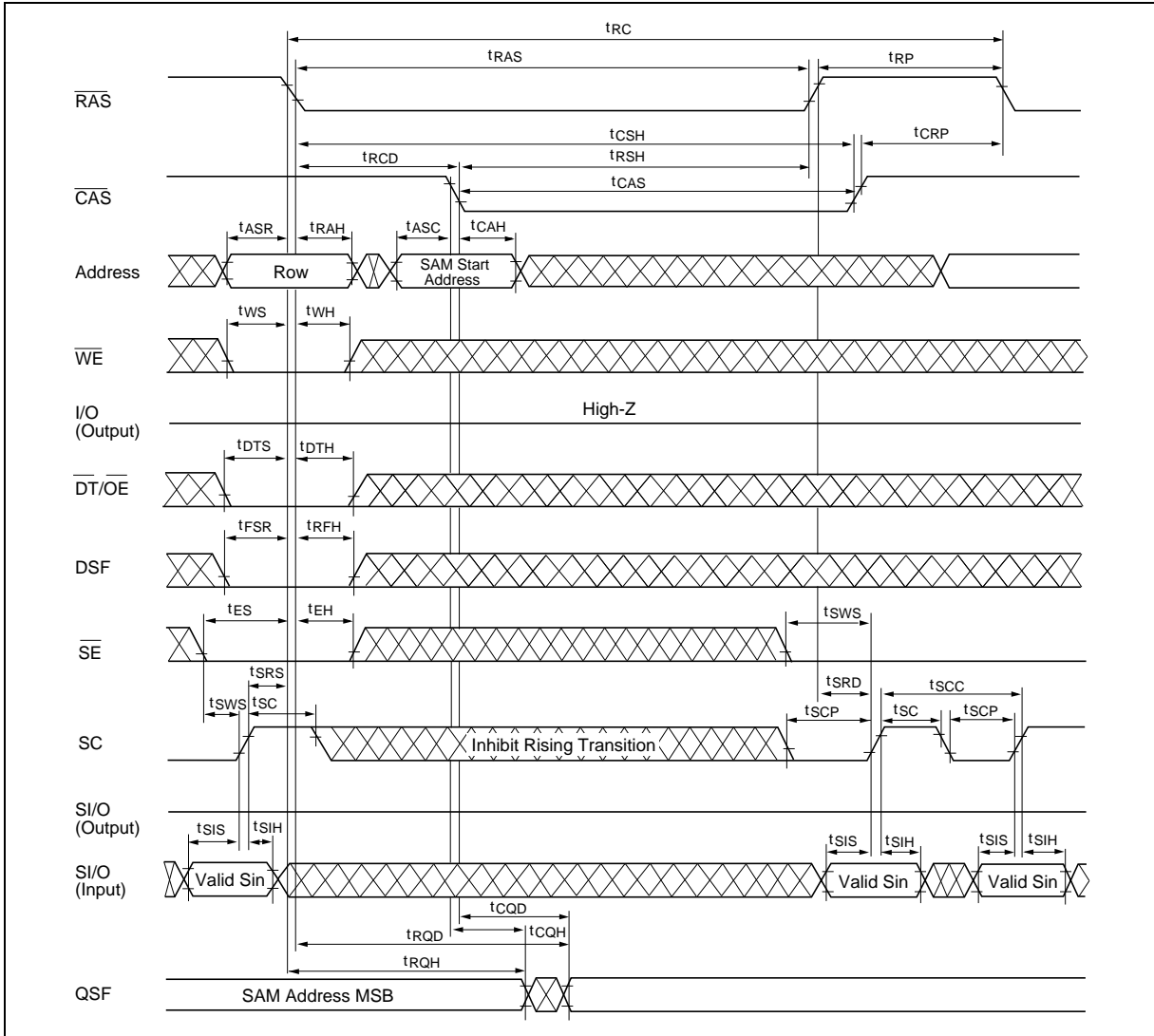

HM538123B Series

Split Write Transfer Cycle

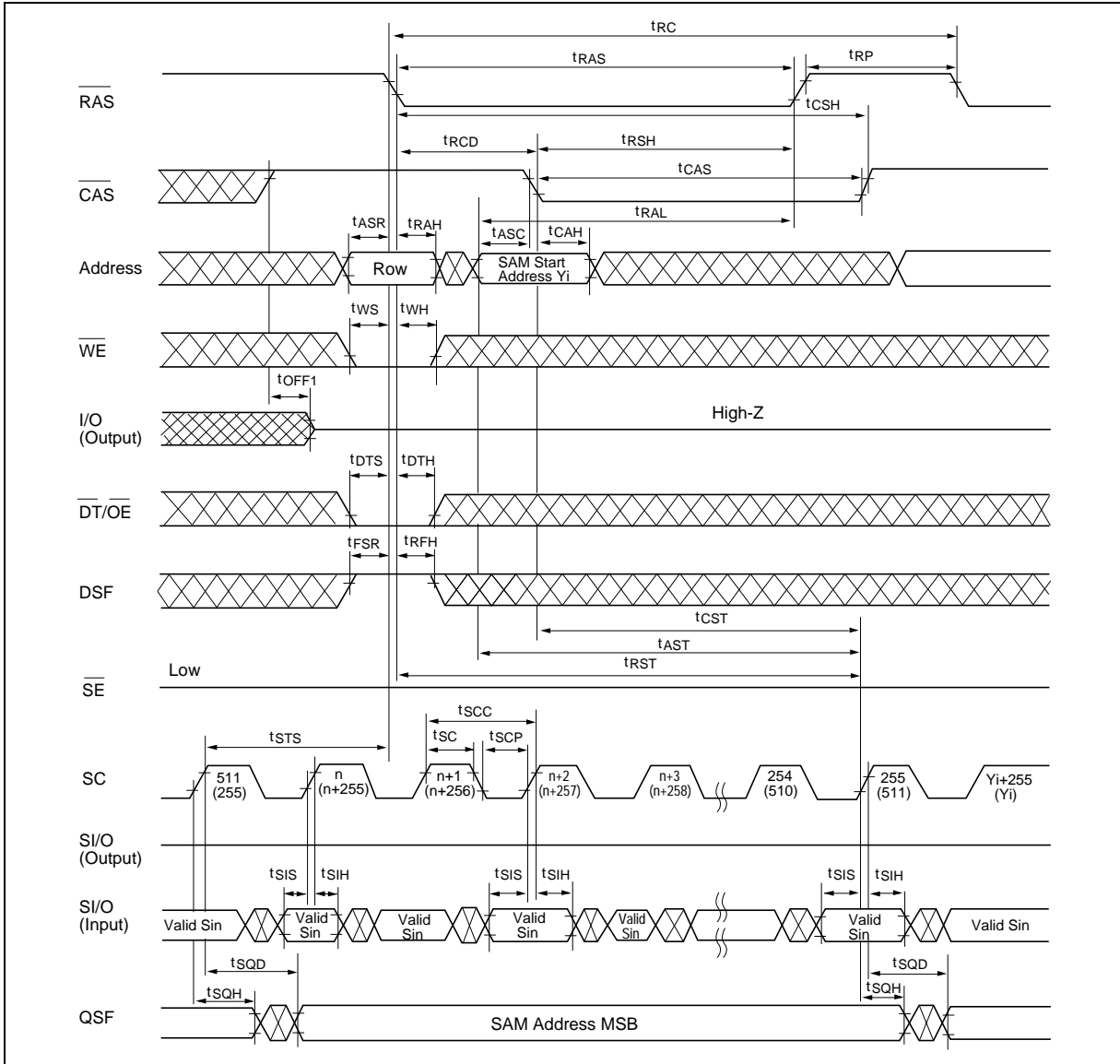

Serial Read Cycle

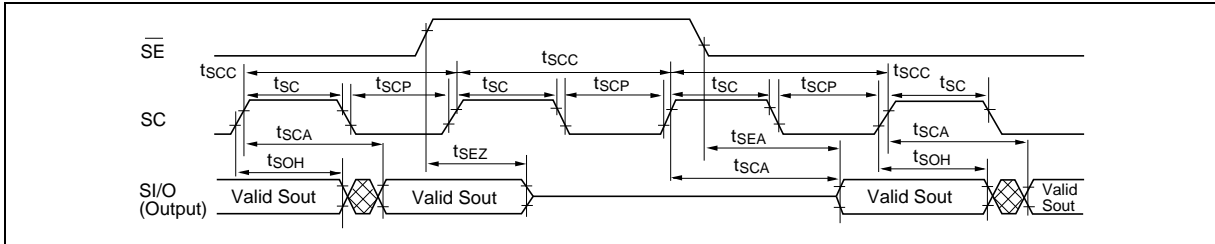

Serial Write Cycle

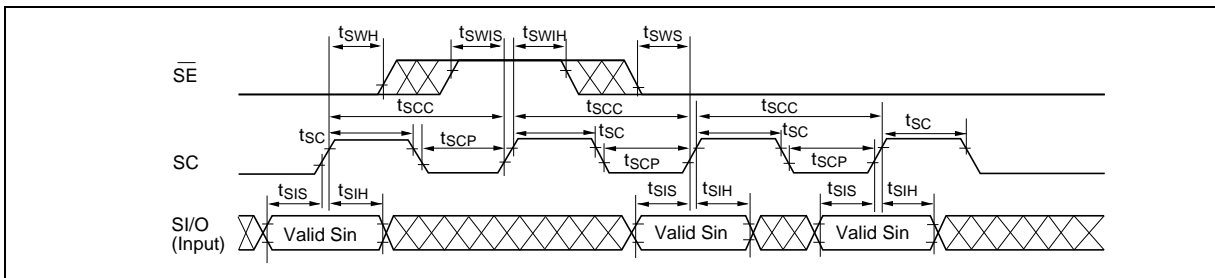

HM538123B Series

Package Dimensions

HM538123BJ Series (CP-40D)

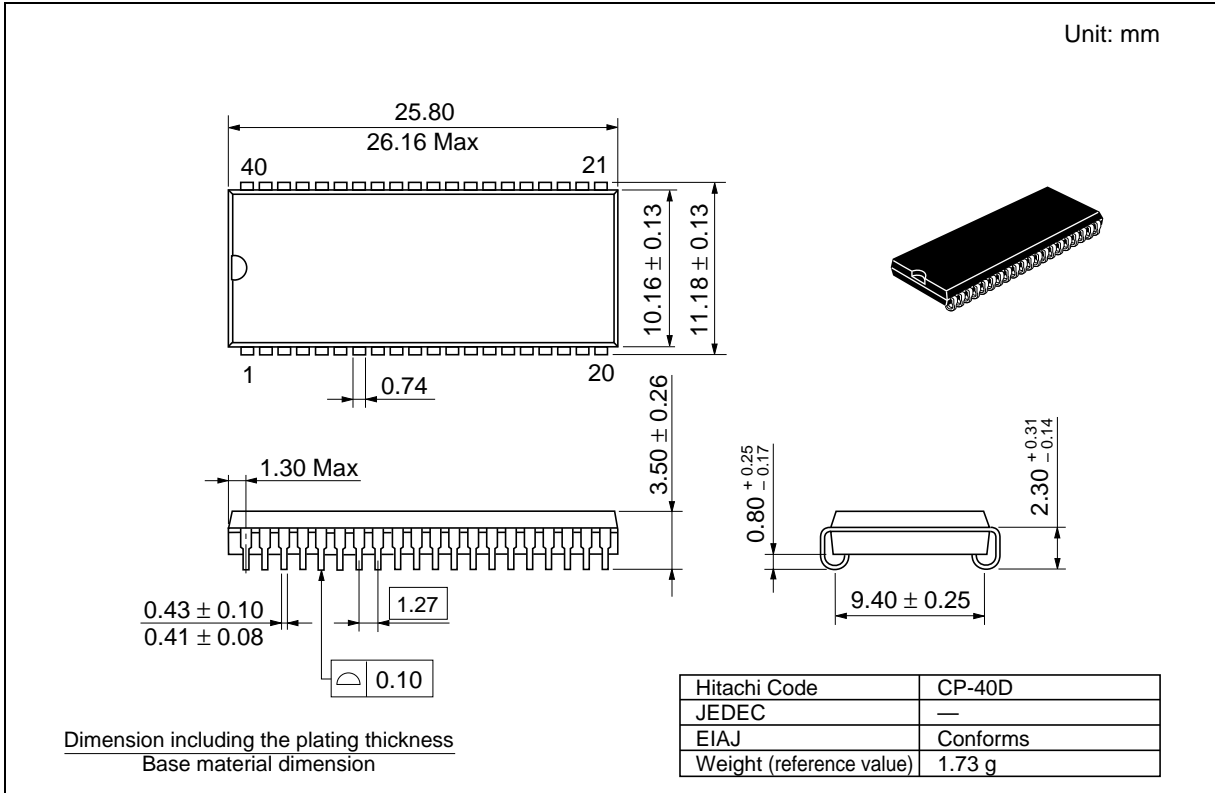

When using this document, keep the following in mind:

1. This document may, wholly or partially, be subject to change without notice.
2. All rights are reserved: No one is permitted to reproduce or duplicate, in any form, the whole or part of this document without Hitachi's permission.
3. Hitachi will not be held responsible for any damage to the user that may result from accidents or any other reasons during operation of the user's unit according to this document.
4. Circuitry and other examples described herein are meant merely to indicate the characteristics and performance of Hitachi's semiconductor products. Hitachi assumes no responsibility for any intellectual property claims or other problems that may result from applications based on the examples described herein.
5. No license is granted by implication or otherwise under any patents or other rights of any third party or Hitachi, Ltd.
6. **MEDICAL APPLICATIONS:** Hitachi's products are not authorized for use in **MEDICAL APPLICATIONS** without the written consent of the appropriate officer of Hitachi's sales company. Such use includes, but is not limited to, use in life support systems. Buyers of Hitachi's products are requested to notify the relevant Hitachi sales offices when planning to use the products in **MEDICAL APPLICATIONS**.

HM538123B Series

Revision Record

Rev.	Date	Contents of Modification	Drawn by	Approved by
1	Mar.18, 1994	Initial issue	M. Takahashi	T. Kizaki
2.0	Dec.8, 1994	Addition of figure 4: Example of row bit data transfer Addition of description about figure 4 for write transfer cycle	M. Takahashi	T. Kizaki
3.0	Apr. 24, 1995	AC Characteristics Addition of t_{SDD2} (min): 25/25/25/25 ns Addition of notes 17 Timing waveforms Read transfer cycle Addition of t_{SDD2} timing Addition of notes 3	M. Takahashi	T. Kizaki
4.0	Nov. 1997	Change of Subtitle		
